

Panduit Pre-Configured Universal Distribution Frame (UDF) Installation Instructions

Part Numbers: ZDF48-***



Figure 1: Front of 26RU Universal Distribution Frame (UDF)

Table of Contents

Safety Information	2
Universal Distribution Frame Overview	3
IDF Preparation and Mounting	3
Fiber Trunk Cable Installation	5
Power Entry and Routing	9
Copper Trunk Cable Installation.....	12
Switch Installation.....	14
Thermal Considerations	18

Safety Information

The information and instructions contained in this document are not intended to be utilized as a substitute for proper training and experience in the safe installation and operation of product. Prior to installation, it is the Buyer's responsibility to consult with the appropriate local Authority Having Jurisdiction (AHJ) for all applicable codes, permits, regulations, and standards. This product, including any equipment that may be installed inside, should only be installed and serviced by a licensed electrical contractor, or competent technician, that meets the following qualifications;

- Is thoroughly familiar with this product and the instructions for installation and operation.
- Is trained (accredited) in industry-accepted safe operating practices and procedures regarding identification and mitigation of high- and low- voltage hazards and situations.
- Is trained to identify and install appropriately-sized Branch Circuit Disconnect(s) with appropriately-sized Branch-Circuit Protective Rating and Short-Circuit Current Rating (SCCR), before connecting Panduit product to the branch circuit.
- Is trained and authorized to energize, de-energize, clear and ground power distribution equipment.
- Is trained in the care and use of PPE (personal protective equipment) including, but not limited to; arc-flash protective clothing, safety glasses, face shield, hard hat, gloves, and non-conductive tools (clamp stick, hot stick, etc.).

Be sure wall is capable of supporting equipment.

DISCLAIMER OF WARRANTIES AND LIMITATION OF LIABILITIES

The practices contained herein are designed as a guide for use by persons having technical skill at their own discretion and risk. Panduit does not guarantee any favorable results or assume any liability in connection with these instructions. Local, State, Federal, and Industry Codes and Regulations, as well as manufacturers requirements, must be consulted before proceeding with any project. Panduit Corp. makes no representations of nor assumes any responsibility for the accuracy or completeness set forth herein. Panduit disclaims any liability arising from any information contained herein or for the absence of same.

For Assistance:

Customer Service

800-777-3300

cs@panduit.com

General Technical Support

TechSupport@panduit.com

Universal Distribution Frame Overview

Panduit's Universal Distribution Frame allows industrial switches to be deployed using EAI 19" rails, while providing an electrically and thermally validated solution.

IDF Preparation and Mounting

1. Open the front door and center section. Open so that there is access to the rear panel of the enclosure.
2. Remove the Recommended Conduit Locations Template from the Back Plate (rolled up in the Tak-Ty).



Figure 2: Location of template

3. Tape the template to the bottom of the IDF enclosure. The bottom outside rear edge of the bend is indicated on the template in [Figure 3](#).

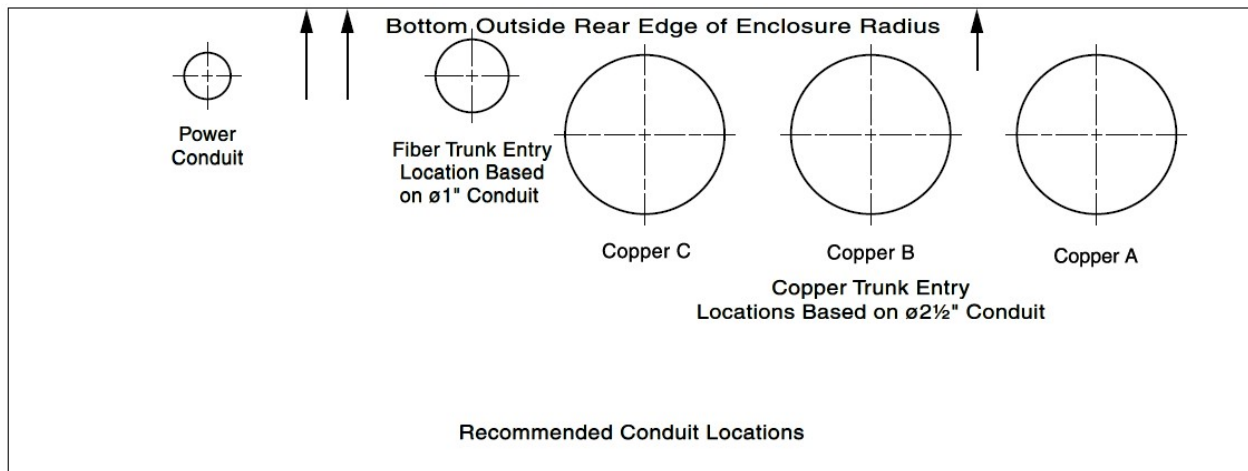

Figure 3: Recommended Conduit Location Template

4. Using the template, mark the desired locations for the external conduit entry on the bottom of the enclosure.
5. Drill and punch all conduit entry positions that will be used in this installation.

- Following the Hoffman Installation Guide, mount the enclosure in the desired location using the 6 holes on the wall section of the enclosure, refer to [Figure 4](#). Reference the part drawing for the area required to fully open the enclosure.

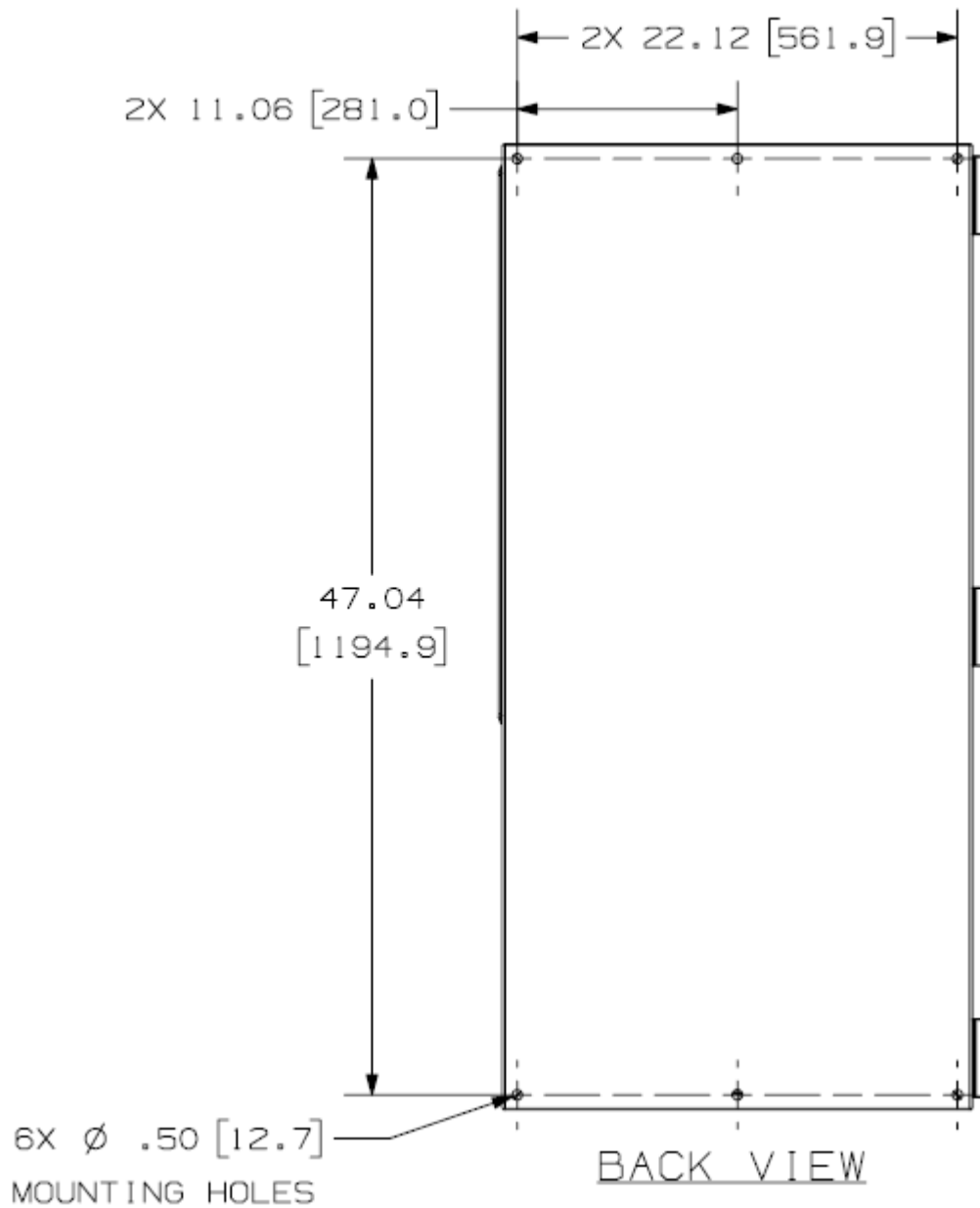

Figure 4: IDF Wall Section Mounting Holes

- Install all conduit connections in the appropriate locations.
- Remove the plastic tabs from the Door and Wall Section edges.



Fiber Trunk Cable Installation

1. Remove the shipping Tak-Ty from the front of the FRME2U Fiber Enclosure shown in [Figure 5](#).

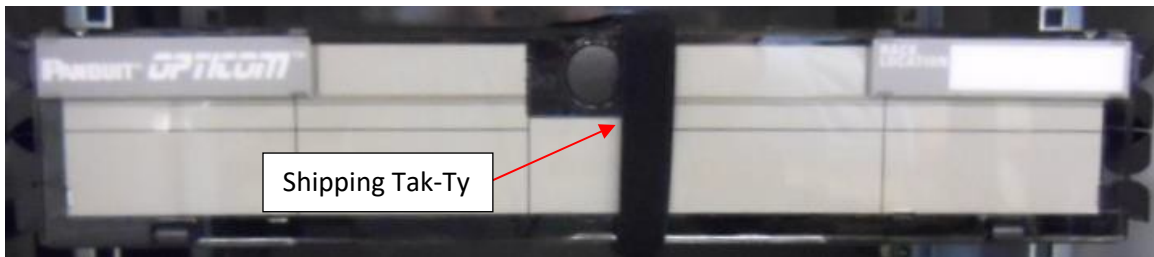

2. *Figure 5: Shipping tape to be removed from FRME1U.*
3. Pull the fiber trunk cables through the conduit(s) into the enclosure.
4. If using armored cable:
 - a. Cut the armored cable for 110" (3m) inside the enclosure. Leaving a stub of bare armor above the conduit.
 - b. Optional: Utilize Panduit's Armored Cable Grounding Jumper Kit (ACG24K, ACG24K-500, ACG24KX-500) to ground the armor of the cable.
5. Route the jacketed fiber cable through the Panduit Duct shown in [Figure 6](#).

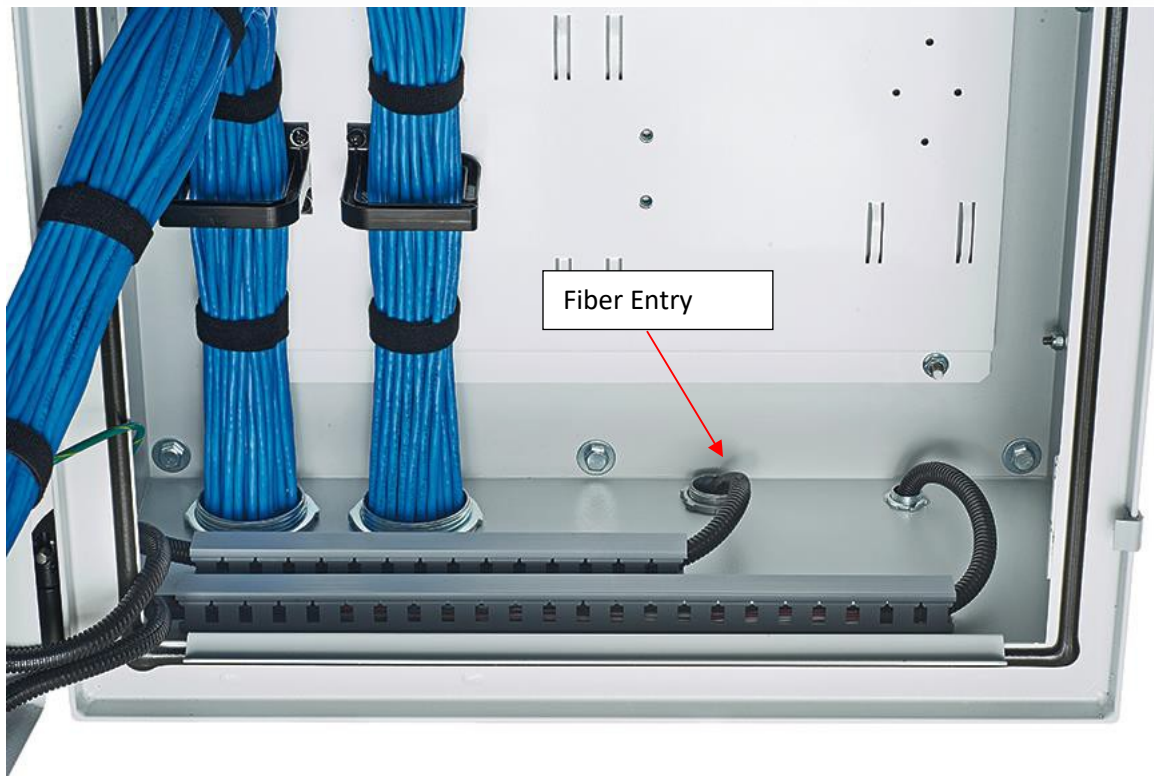

Figure 6: Fiber Trunk Entry

6. Route the jacketed cable through the abrasion protection supplied in the miscellaneous kit. The tubing protects the fiber from getting pinched in the hinge.



Figure 7: Loom tubing routed around hinge point and rail.

7. Install the cable into the FRME2U Fiber Enclosure per FS002C, Opticom Rack Mount Fiber Enclosure Installation Instructions.
 - a. Install fiber adapter panels in the FRME2U. Panduit recommends FAP12WAQDLCZ multi-mode FAPs for switch connections (ordered separately). FAP is recommended for management ports in the right FAP position in the enclosure

- b. Remove the pre-installed Fiber Bend Radius Control Clips from the front of the enclosure. This allows the inner drawer to be pulled back towards the rear of the enclosure.
- c. Remove the cable entry grommet from the rear of the fiber enclosure.
- d. Route the jacketed fiber through cable entry grommet.
- e. Remove approximately 39" of the fiber jacket exposing the buffered fiber inside.
- f. Field-terminate the required fiber adapters onto the fiber.
- g. Re-insert the grommet back into the Fiber Enclosure.
- h. Route the Fiber Cable as shown in **Figure 8**. The fiber entry for this application is on the **left** side of the enclosure (when facing from the front). Use Tak-Ty to secure fiber cords at the cable entry location and other points as shown.
- i. Route the buffered fiber around the spools as shown.
- j. Insert the fiber connectors into the desired pre-installed fiber adapter panel (FAP) locations in the enclosure. Note that the FAPs can be easily removed via push pull latches on the faceplates.

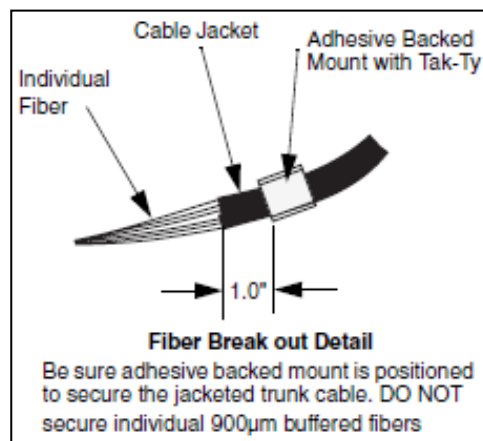
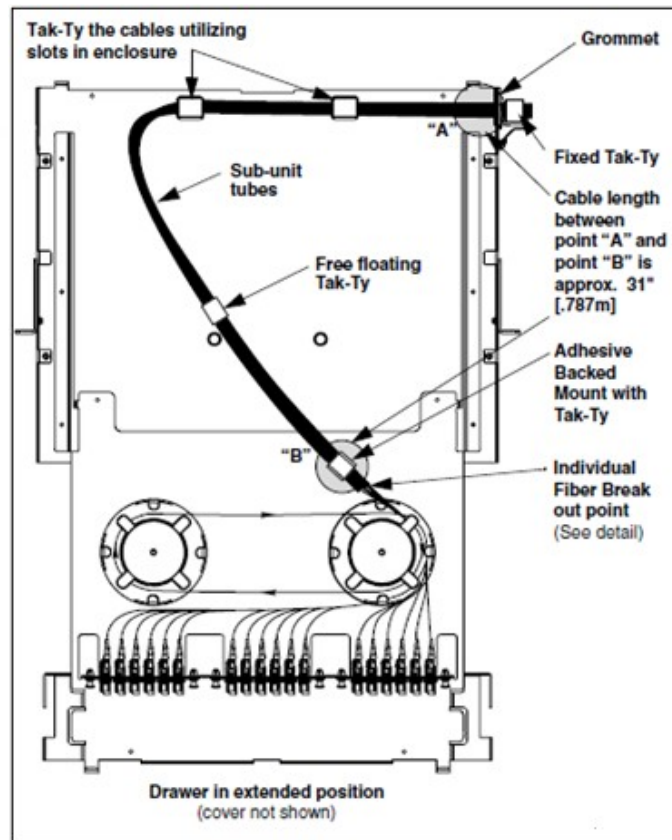

Figure 8: FRME2U Fiber Enclosure Cable Routing

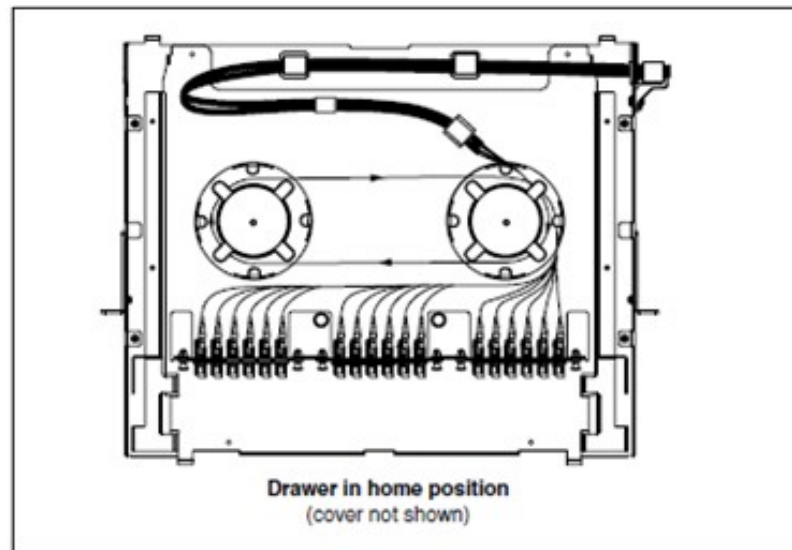

Figure 9: Fiber Enclosure Drawer showing the fiber cable when the drawer is closed.

Power Entry and Routing

1. Bring the power cable into the enclosure through the hole punched during installation.

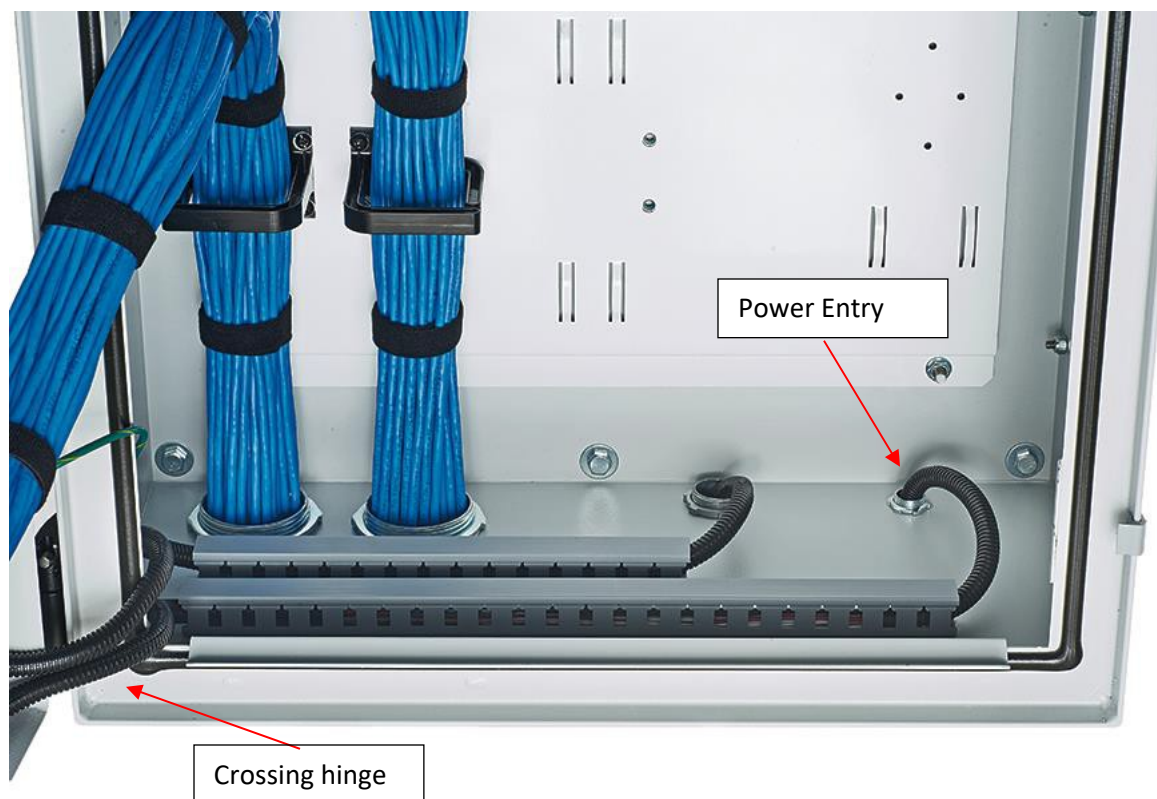

Figure 10: Power Cable Entry

2. Using the included abrasion protection, route the power cables through the front (longer) piece of duct in the back section of the enclosure.

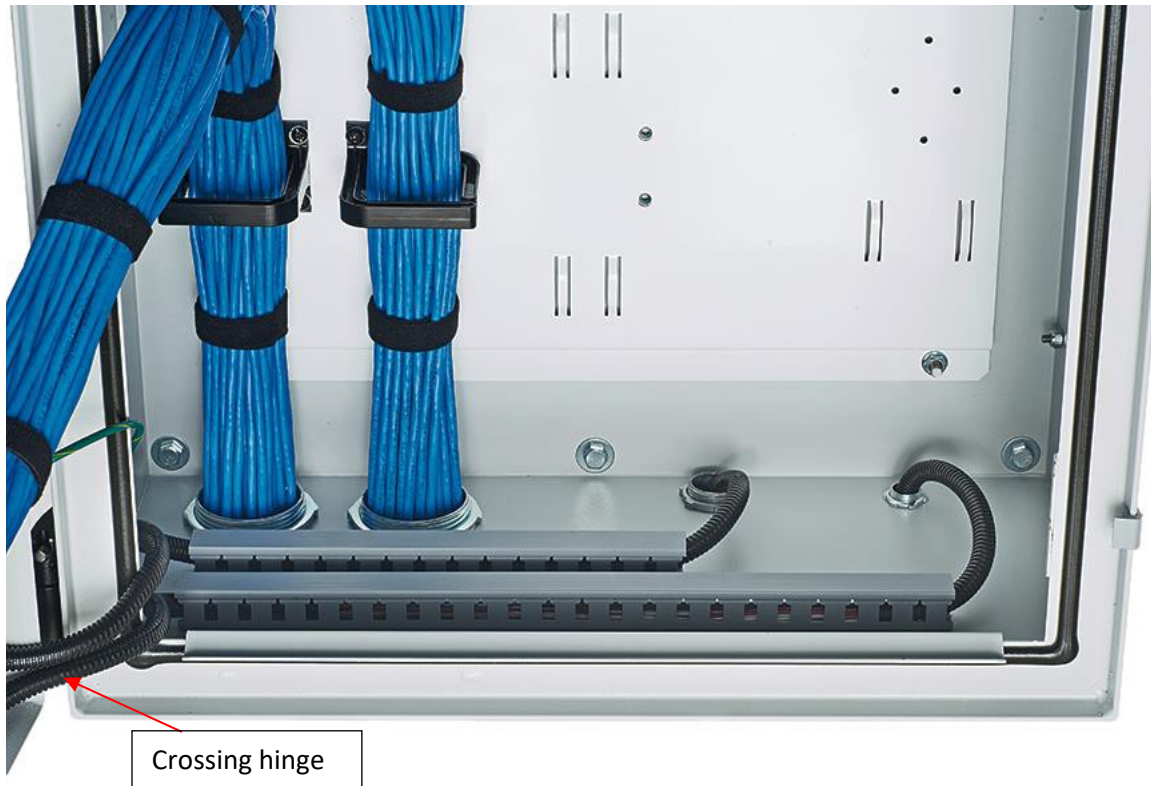

Figure 11 - Power cables crossing hinge

3. Route power cables through the duct located at the bottom of the middle section of the IDF and then use the included Tak-Ty hook and loop to route the power cables to the bottom tier. Refer to Field Wiring Diagram on how to connect the incoming power cables.



Routing
through duct

Figure 12 - Routing power cable across the hinge and through the duct

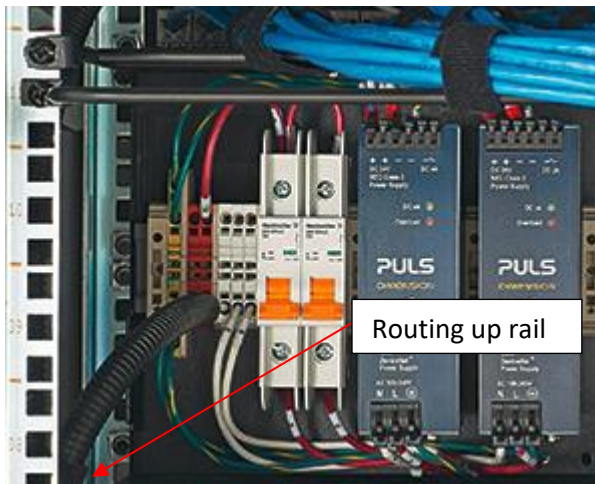

Routing up rail

Figure 13 - Routing power up the rail to the bottom tier

Copper Trunk Cable Installation

8. Pull the Copper-A trunk cable through the conduit into the enclosure.
9. Route the Copper-A trunk cable up the left side of the rear Backplane, refer to [Figure 14](#). Use the Tak-Ty and D-ring provided to secure the cable to the Backplane. 78" of slack (measured from enclosure bottom) is required in the enclosure. This leaves 2" of cable to terminate onto the copper jacks.



Figure 14: Copper Cable Routing showing Copper-A on the left and Copper-B cables in the middle, and Copper-C cables on the right

10. Bundle the cable in sets of (4) to be installed into the patch panel.
11. Terminate the cables onto CJ688TGxx copper jacks (ordered separately) per PN403L, *TX6 PLUS and TX5e UTP Jack Module Installation Instructions*.
12. Attach the cables to the installed Strain Relief Bar using Tak-Ty in the miscellaneous carton. This is shown in [Figure 15](#).
13. Route the cables along the rear strain relief bar as shown in [Figure 16](#).



Figure 15: Copper Cables Tak-Ty to the Strain Relief Bars



Figure 16: Copper-A (lower) and Copper-B (upper) copper cable bundles attached to the rear strain relief bars.

14. Pull the Copper-B trunk cable through the conduit into the enclosure.
15. Route the Copper-B trunk cable up the center of the rear Base Plate, refer to [Figure 14](#). Use the Tak-Ty and D-ring provided to secure the cable to the Backplane. 64" of slack (measured from enclosure bottom) is required in the enclosure. This leaves enough cable to terminate onto the copper jacks.
16. Route the cables along the strain relief bars as shown in [Figure 15](#) and [Figure 16](#).
17. Optional: Apply the supplied labels and covers to the front of the patch panel to create TIA-606 compliant labeling.
18. Repeat above steps for the Copper-B copper trunk cable, Copper-C copper trunk cable, and upper patch panels.

Switch Installation

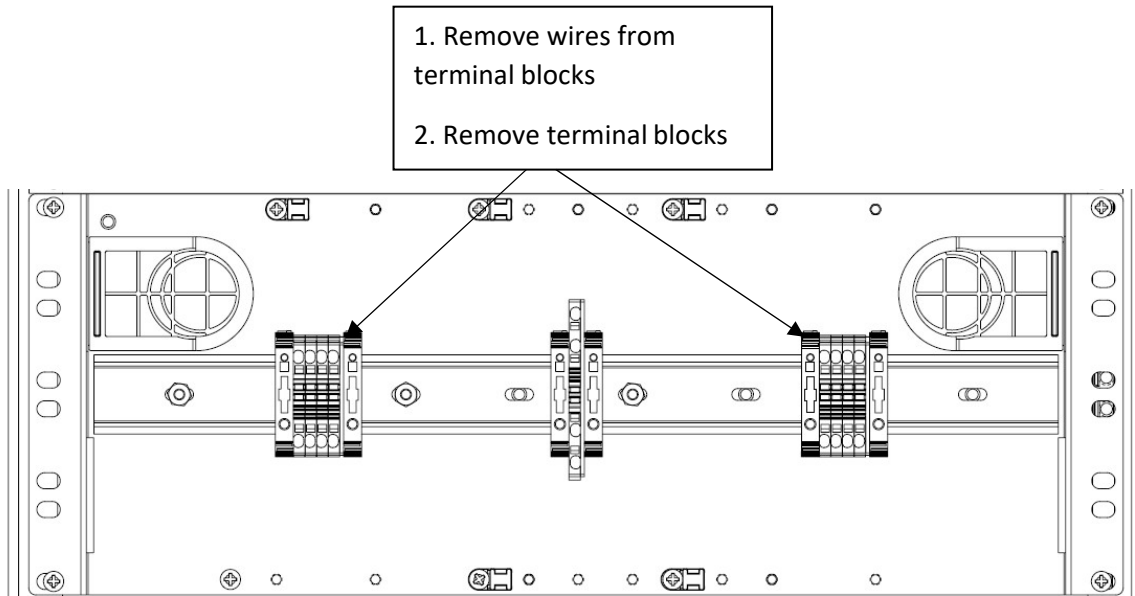
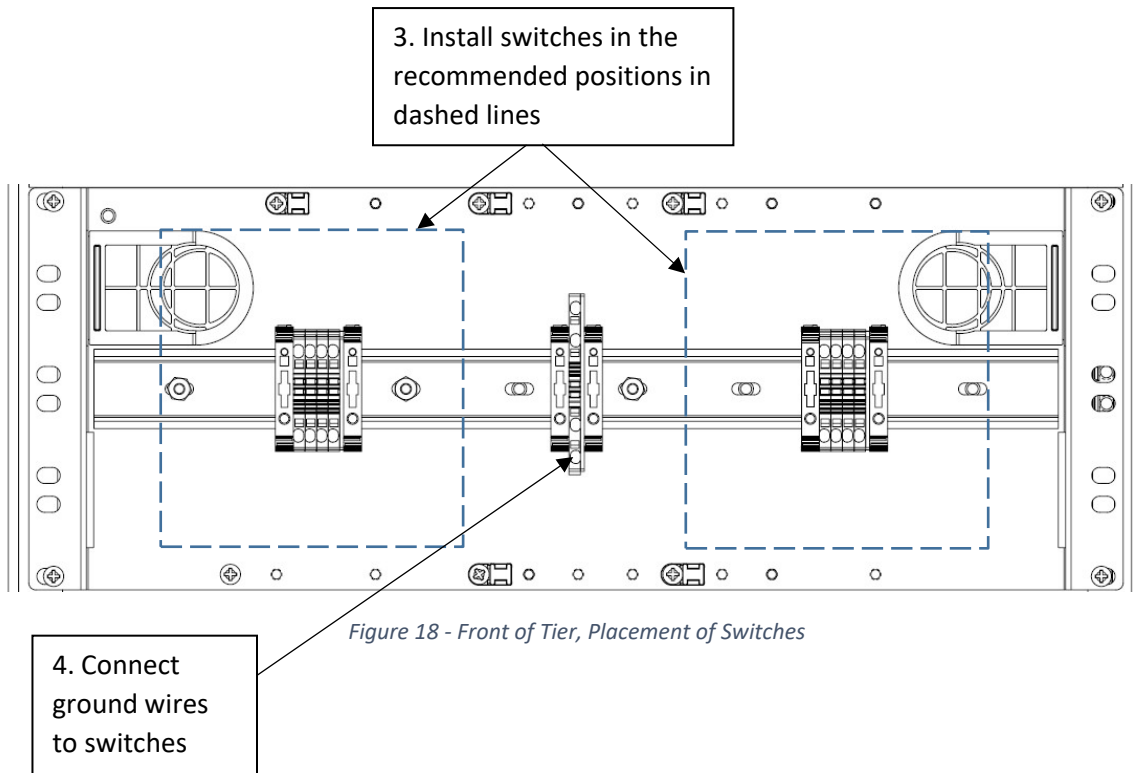

Figure 17 - Front of Tier, Removing Terminal Blocks

1. Remove wires from terminal blocks.

NOTE: Do not apply power prior to terminal block removal and switch installation.

2. Remove terminal blocks.



3. Install switch using manufacturer's recommendation. You may need to remove or slide out the item in the RU directly above the switch to be able to snap the switch onto the DIN rail.

4. Install supplied ground wire to each switch. See manufacturer's instructions for how to ground the switch.

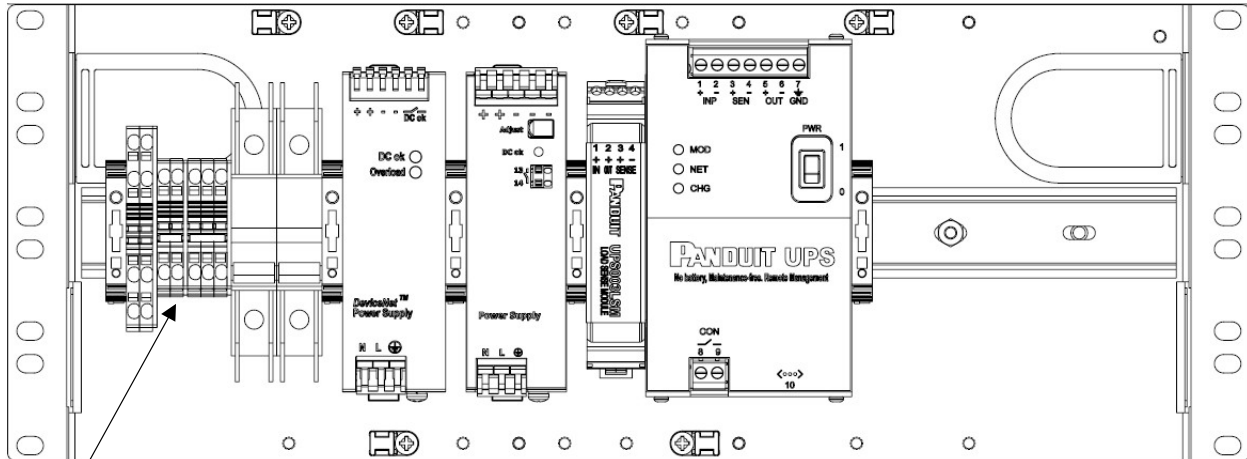

Figure 19 - Rear of Tier, Configuration shown includes Panduit 100W UPS (not included with all part numbers)

5. Wire up incoming power to the bottom tier.

5. Wire switch and connect power to the bottom tier – Refer to switch manufacturer’s instructions and supplied Field Wiring Diagram for proper wiring technique. Make sure circuit breakers are in the OFF position while wiring.

NOTE: Do not apply power prior to terminal block removal and switch installation.

6. Install patch cords as needed, lengths may vary depending on the switch installed.

7. Use the fiber spools on the side of the enclosure to route fiber patch cords back to the fiber enclosure

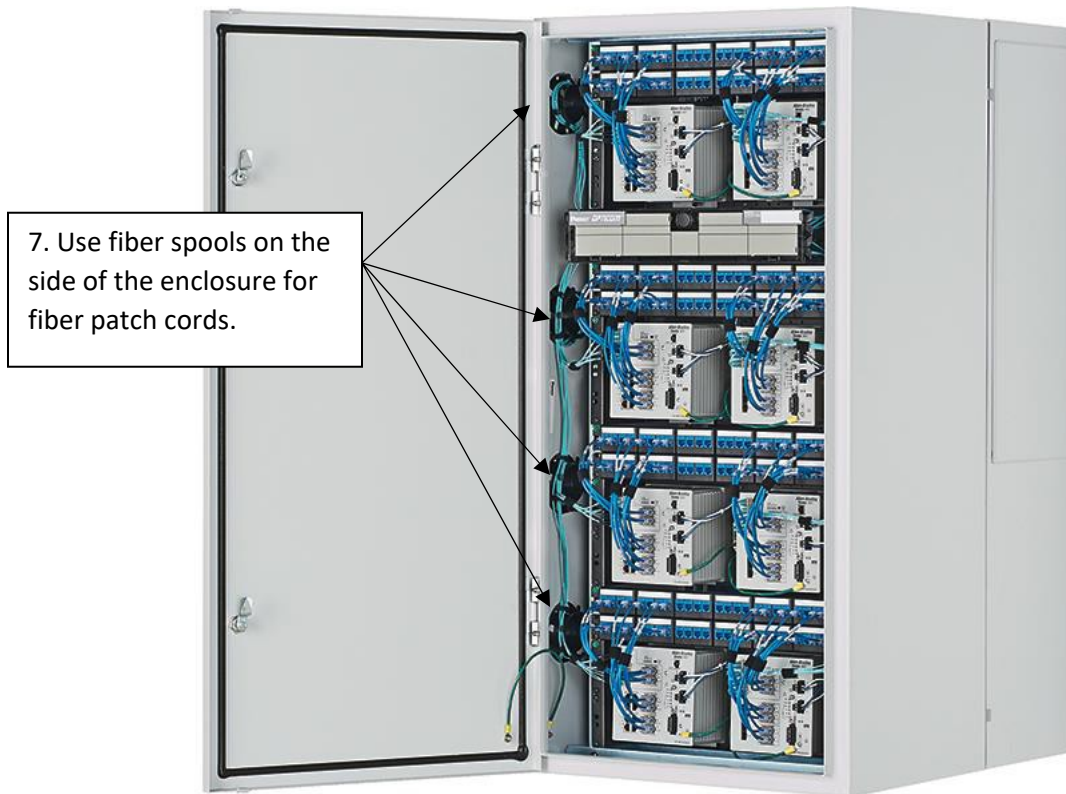

Figure 20 - A fully installed 26RU UDF

Thermal Considerations

Please use the below as a reference for the total thermal load that Panduit Intermediate Distribution Frames can support.

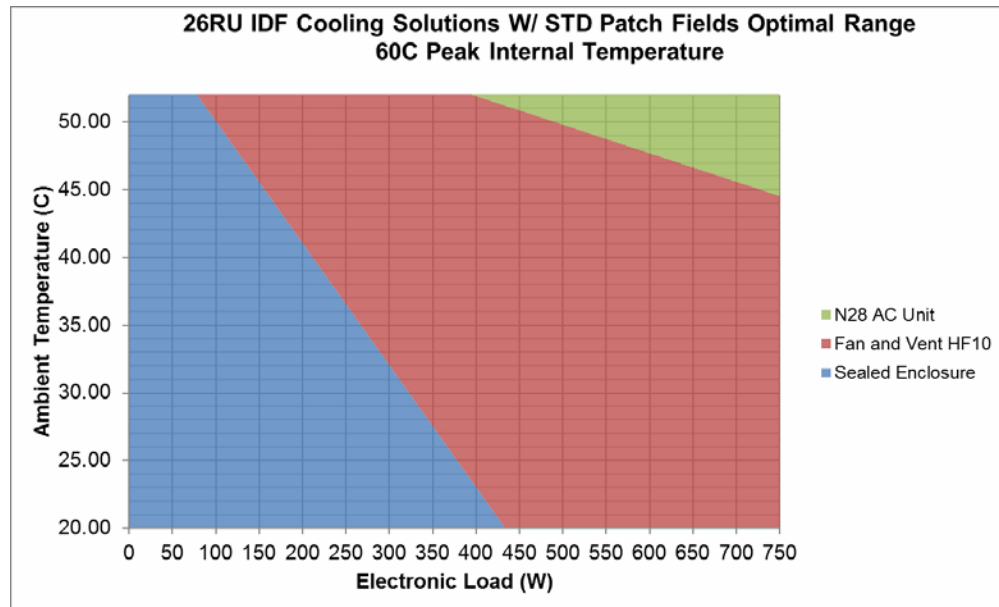

Figure 21: 26RU UDF enclosure guidelines for three recommended thermal solutions. The examples below demonstrate how to use this graph.

Example 1: An electronic load of 200 watts (sum of heat dissipation of the electronics inside the UDF). A peak ambient temperature of 35 °C (temperature outside the enclosure).

Answer 1: The intersection of the vertical 200 w line and the horizontal 35 °C line is in the blue area. Therefore, the UDF enclosure will adequately dissipate the heat and the peak internal temperature inside the UDF will not exceed 60 °C.

Example 2: An electronic load of 300 watts. A peak ambient temperature of 40 °C (temperature outside the enclosure).

Answer 2: The intersection of the vertical 300 w line and the horizontal 40 °C line is in the red area. Therefore, a fan and vent are required to keep the internal temperature of the UDF enclosure below 60 °C.

Example 3: An electronic load of 550 watts. A peak ambient temperature of 50 °C (temperature outside the enclosure).

Answer 3: The intersection of the vertical 550 w line and the horizontal 50 °C line is in the green area. Therefore, a N28 air conditioner is required to keep the internal temperature of the UDF enclosure below 60 °C.

Note: For more information about how to deploy a Universal Distribution Frame, please see the Universal Distribution Frame Thermal Management Application Guide.