

LAB MANNUAL
ON
ELECTRICAL MACHINE LAB -1

Branch: ELECTRICAL ENGINEERING

Subject code: Pr-1

Class: Diploma 4th Semester



ITT CHOUDWAR.

Department - Electrical

INDEX

Experiment -1

Sl. No	List of Experiments	Page No.
1	Identification of different terminals of a dc machine by lamp method & multi-meter method and to measure insulation resistance by megger.	3-6
2	Dimensional and material study of various parts of a dc machine.	7-14
3	Plot OCC of a DC shunt generator at constant speed and determine critical resistance from the graph.	15-17
4	Plot External Characteristics of a DC shunt generator at constant speed.	18-20
5	Study of three-point starter, connect and run a dc shunt motor and measure the no-load current.	21-24
6	Study of four-point starter, connect and run a dc compound motor and measure no-load current.	25-27
7	Control the speed of a dc shunt motor by field control method, control the speed of a dc shunt motor by field flux control method & armature voltage control method.	28-32
8	Determine the armature current vs. speed characteristic of a DC motor	33-37
9	Determine the efficiency of a DC machine by brake test method.	38-40
10	Identification of terminals, determination of voltage transformation ratio of a single-phase transformer.	41-44
11	Perform OC Test and SC test of a single phase transformer	45-48
12	Determine the voltage regulation of a single phase transformer at different loads.	49-51
13	Polarity test of single phase transformer and parallel operation of two single phase transformers	52-56

Experiment -1

AIM OF THE EXPERIMENT-: Identification of different terminals of a DC machine by test lamp method and multi-meter method & to measure insulation resistance by megger.

APPARATUS REQUIRED:

Sl.no	Name of the Equipment	Specification	Quantity
1	DC Compound Motor	220v, 3 KW, 1500 RPM, 12A	1no
2	Insulated Combination Pliers	150mm	1no
3	Screw driver	200mm	1no
4	Series test lamp board	220V	1no
5	Megger	100M Ω	1 no
6	Connection wires		As per required

THEORY:

A dc motor mainly consists of two windings as (a) Armature winding (b) field winding. In case of series dc motor field contain series winding only while shunt motor field contain shunt field winding but in case of compound wound dc motor field winding contain both series and shunt winding since each winding has two terminals in case of compound wound motor. There are three winding 6 terminals which located at top and attached with it.

To identify the terminals and measure the insulating resistance of the winding. Let consider a dc compound wound motor which has three winding and six terminals are kept in a terminal box and attached with a yoke or frame of the motor. The equivalent circuit diagrams of this motor with its terminals are given in the figure for observation point of view.

INSULATION RESISTANCE TEST (BETWEEN WINDING AND BODY)

The aim of this test is that there should be no wire touching of the body. The "F" terminal of megger is connected to the body and 1 terminal should touch the terminal of the generator or motor one by one and rotate the handle at 160 rpm. Note the reading.

INSULATION RESISTANCE TEST (BETWEEN DIFFERENT TERMINALS)

The aim of this test is to check that the winding which should be insulated from each other are insulated or not. For this test touch the "F" terminal of the megger with shunt field winding Z1&Z2 terminal and "L" terminal of the megger to armature terminal A1 & A2 and rotate the handle of the megger. If the megger shows "infinite", it means that there is high resistance between two windings. If the megger shows zero it means that the both winding are short circuited with each other. Then test between A1 or A2, Y1 or Y2, Z1 or Z2 .

DIAGRAMS:

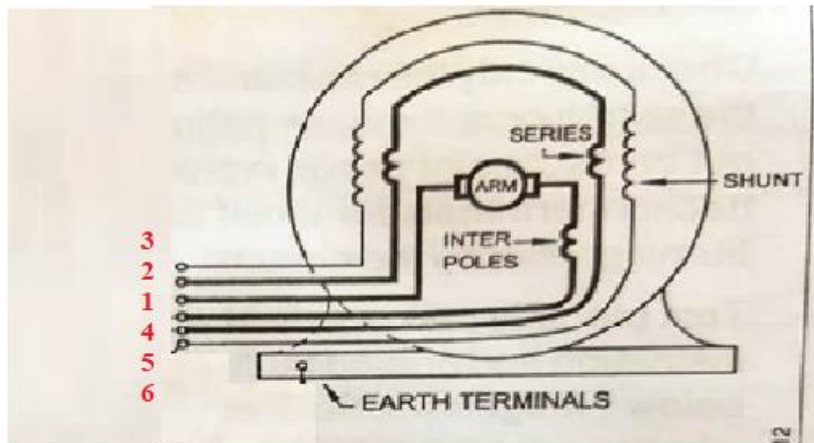

INTERNAL DIAGRAM OF DC MACHINE

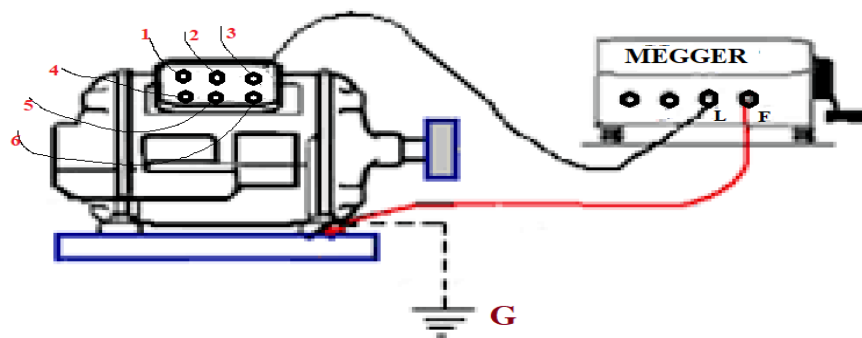

INSULATION RESISTANCE MEASURED BY MEGGER

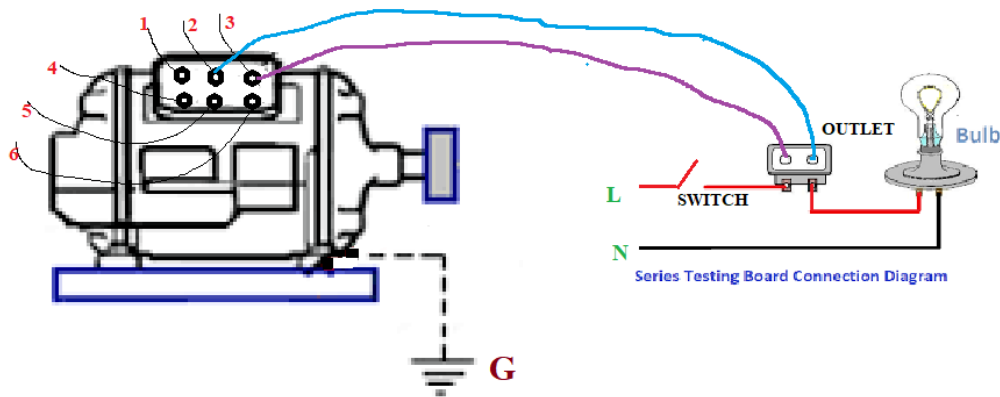

Fig. 2 - DIAGRAM FOR TERMINAL IDENTIFICATION OF A DC MACHINE BY USING SERIES TEST LAMP

PROCEDURE:

- 1) Open all the terminal connection of the dc compound motor.
- 2) Give supply to series test lamp.
- 3) Connect the series test lamp to the terminals of dc compound motor in hit and trial method.
- 4) when the bulb glows, it shows that the terminals are of same winding.
- 5) now connect the megger to the dc motor terminals to check the terminals and measure the insulation resistance of the windings.
- 6) now connect the multimeter to check the resistance of different windings and specify them

OBSERVATION TABLE:

Sl no	Terminals connected to series test lamp	Lamp glows (Y/N)	Pair of terminals(Y/N)	Remarks
1	1-2			
2	1-3			
3	1-4			
4	1-5			
5	2-4			
6	2-5			
7	2-6			
8	3-5			
9	3-6			

TERMINAL IDENTIFICATION:

Sl No	Assume of pairs of terminals	Terminal of exact pairs	Types of winding	Resistance of Winding (ohm)	Insulation Resistance of winding (megaohm)
1	1-4				
2	2-5				
3	3-6				

CONCLUSION:

From this experiment, we learnt about the identification of different terminals of a DC machine.

DISCUSSION QUESTIONS

1. Describe the working of megger?

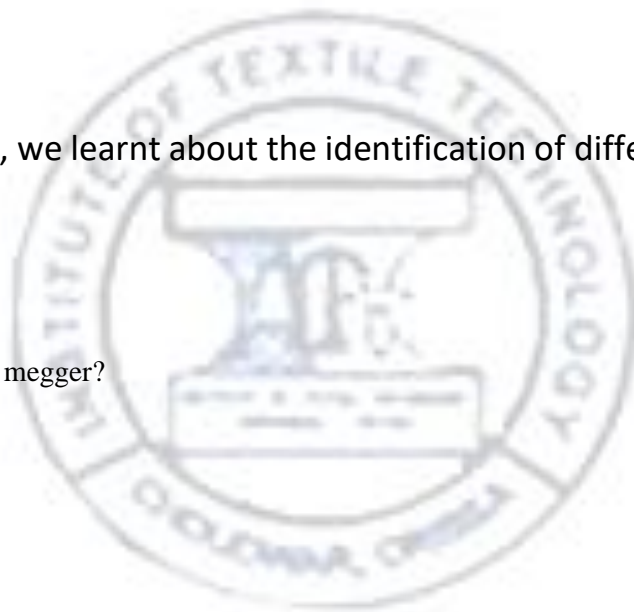

ITT CHOUDWAR

Experiment – 2

AIM OF THE EXPERIMENT-: Dimensional and material study of various parts of a DC machine.

APPARATUS REQUIRED:

Sl.no	Name of the Equipment	Specification	Quantity
1	DC Compound Motor	220v, 3KW, 1500 RPM, 11.8 A	1no
2	Insulated Combination Pliers	150mm	1no
3	Screw driver	200mm	1no
4	Series test lamp board	220V	1no
5	Double ended Spanner	-----	1 Set
6	Connection wires		As per required

THEORY:

MACHINE-: A piece of equipment with moving parts that is designed to do a particular job. A machine usually needs electricity, gas, steam etc. in order to work.

DC MACHINE-: The machine which works on dc supply is called dc machine.

PARTS OF DC MACHINE-:

1. **Frame or Yoke**
2. **Field poles and pole-shoes**
3. **Field coils or Field winding**
4. **Armature Core**
5. **Armature Winding**
6. **Terminal Box**
7. **Brushes**
8. **Bearing & End plate**
9. **Cooling fan**
10. **Commutator**
11. **Shaft**
12. **Name Plate**

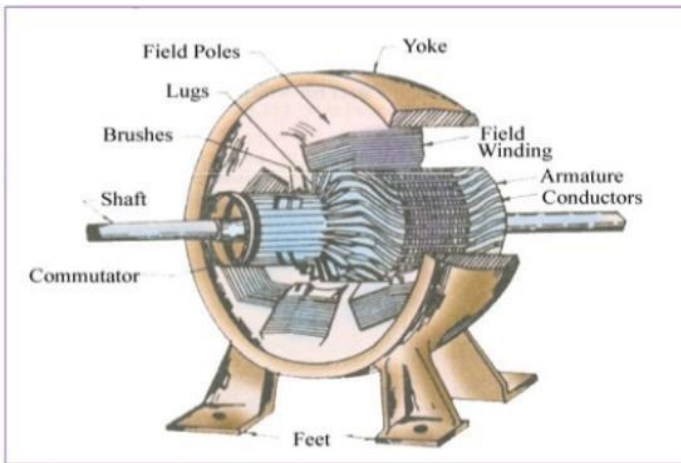

Frame or Yoke: -

The outer frame or yoke serves a dual purpose. Firstly, it provides mechanical support for the poles and acts as a protecting cover for the whole machine. Secondly, it allows the magnetic circuit to complete through it. In small generators where cheapness rather than weight is the main consideration, yokes are made of cast iron. But for large machines usually cast steel or rolled steel is used. Yokes possess sufficient mechanical strength and have high permeability.

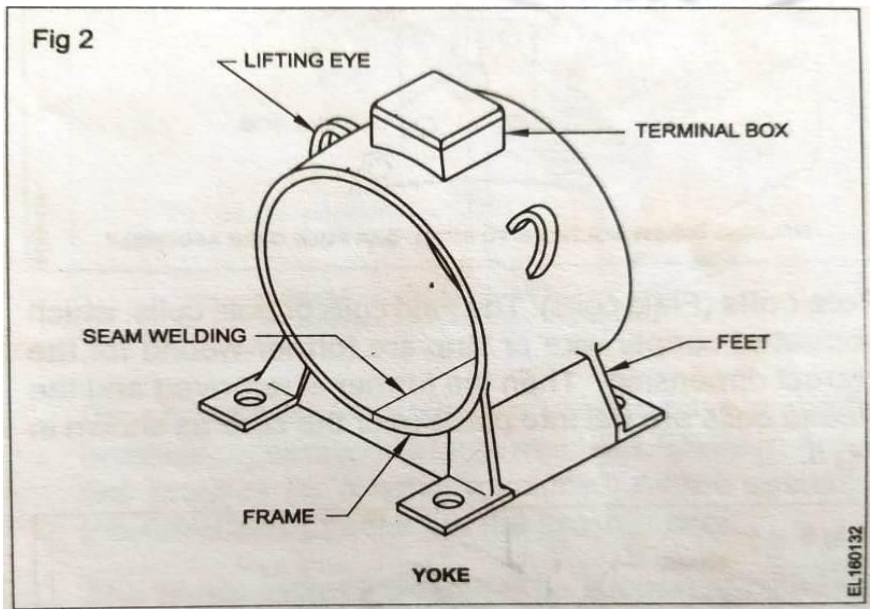

Field poles and pole-shoes: -

The field magnets consist of pole cores and pole shoes. The pole shoes serves two purposes; (i) they spread out the flux in the air gap uniformly and also, being of a large cross-section reduce the reluctance of the magnetic path, and (ii) they also support the field coils. There are two main types of pole construction. The pole core itself may be solid piece made out of either cast iron or cast steel but the pole shoe is laminated and is fastened to the pole face by means of countersunk screws. In modern design, the complete pole cores and pole shoes are built of thin laminations of annealed steel which are riveted together under hydraulic pressure. The thickness of laminations varies from 1mm to 0.25mm.

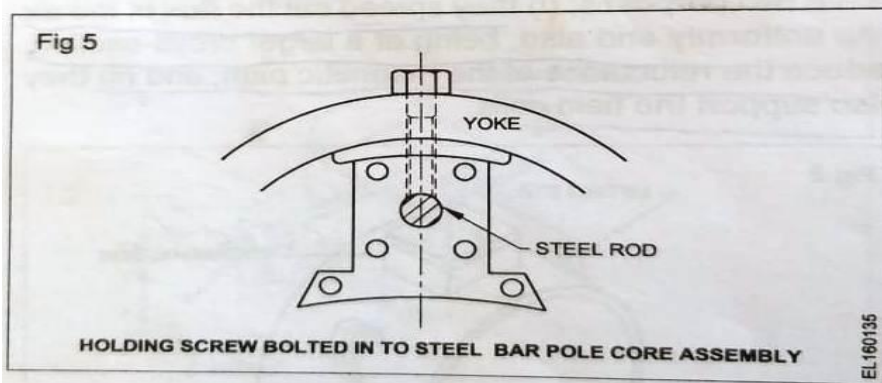
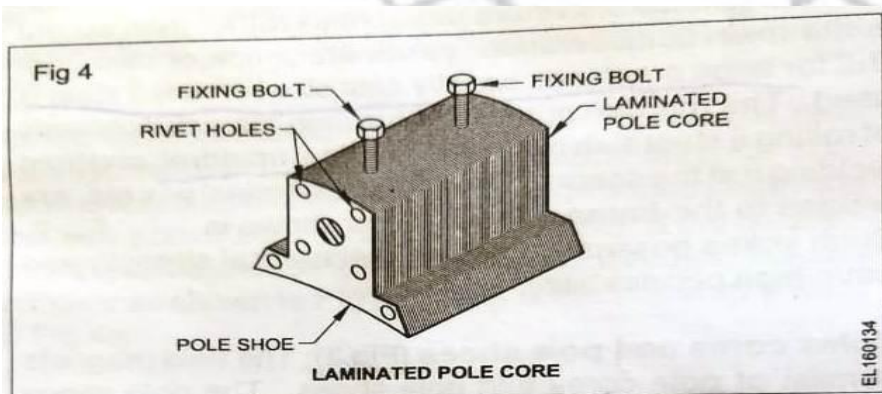
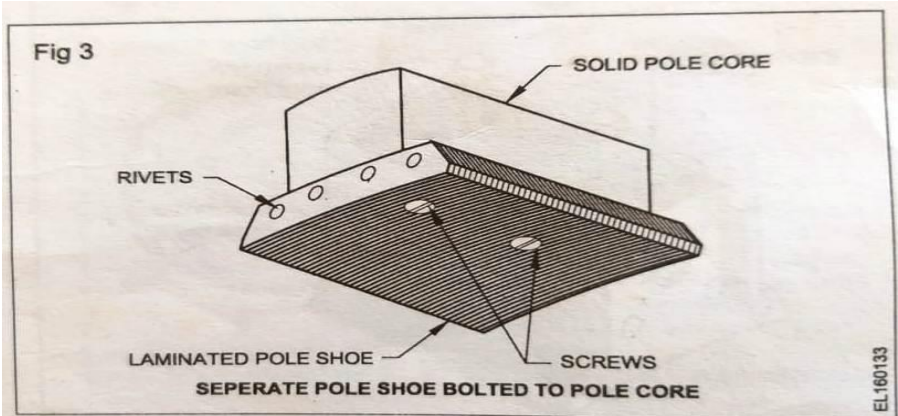

Field coils or Field winding: -

The field coils or pole coils which consist of copper wire are wound on a former for correct dimension. Then the former is removed and the wound coils are put into place over the core. When a current is passed through the coils, they magnetize the poles which produce the necessary flux that is cut by revolving armature conductors.

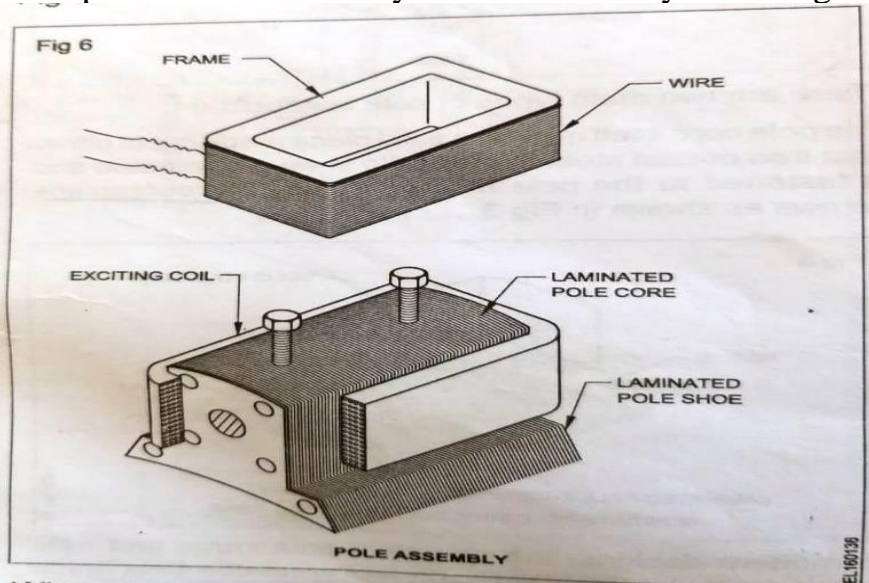

Armature Core :-

The armature core houses the armature conductors. Those conductors are rotate in the magnetic field which cut the magnetic flux. The most important function is to provide a path of very low reluctance to the field flux and allowing the magnetic circuit to complete through the yoke and the poles. The armature core is cylindrical or drum shaped and is build up of circular sheet steel dices or laminations which have 0.5mm thickness.

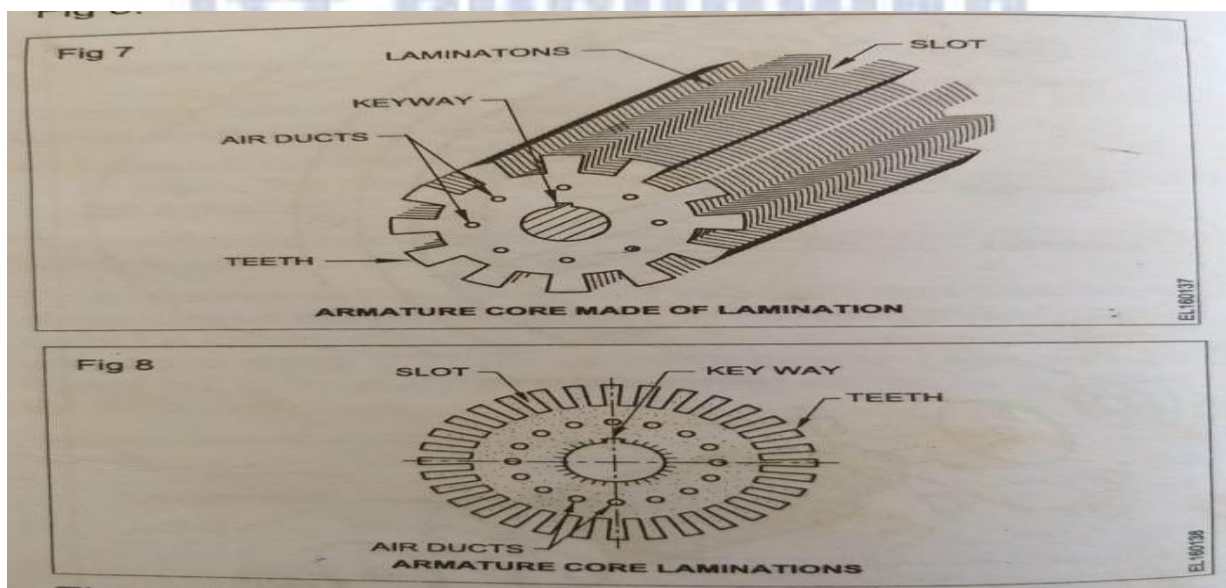

Armature Winding/Armature Conductor: -

the armature windings are usually former-wound. These are first wound in the form of flat rectangular coils and are then pulled into their proper shape with a coil puller. Various conductors of the coils are insulated from each other. The conductors are placed in the armature slots which are lined with tough insulating material. After placing the conductors in the slot, this slot insulation is folded over the armature conductors, and is secured in place by special, hard, wooden or fiber wedges.

Commutator: -

The function of the commutator is to collection of current from the armature conductors. It rectifies i.e. converts the alternating current induced in the armature conductors into unidirectional current for the external load circuit. It is shape like cylindrical structure and made of hard drawn or drop-forged copper. Its segments are insulated from each other by thin layer of mica.

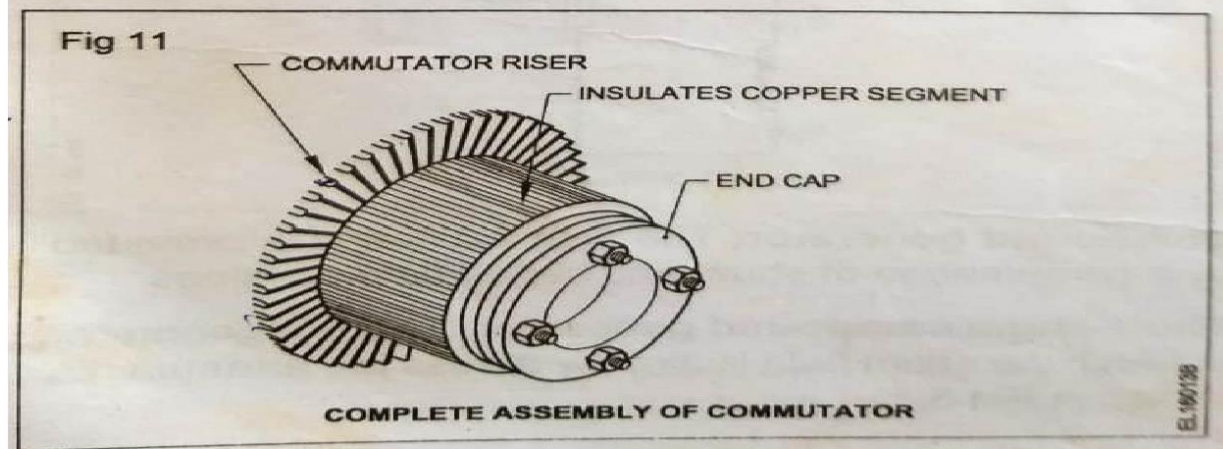
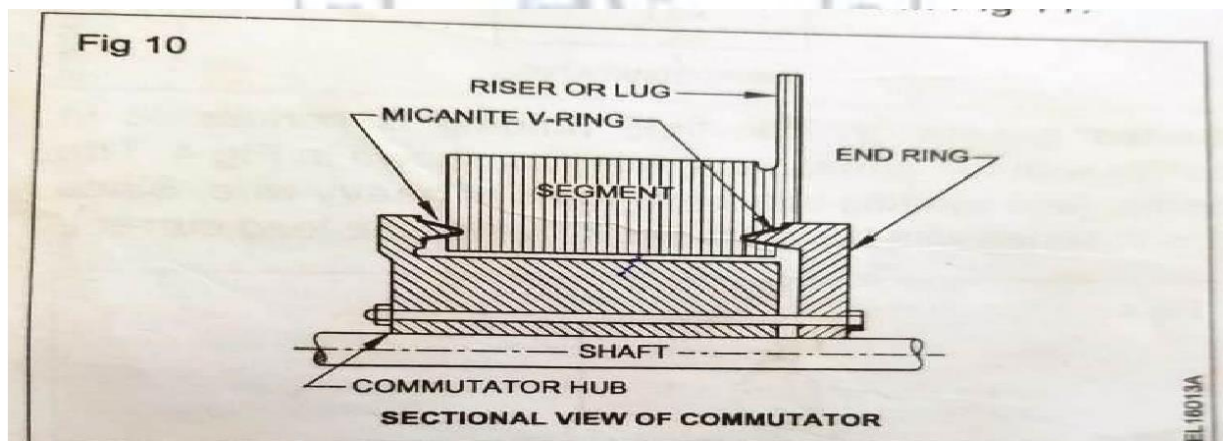

Brush: -

The main function of brush is to collect current from the commutator. These are made of carbon and graphite and are in shape of rectangular block.

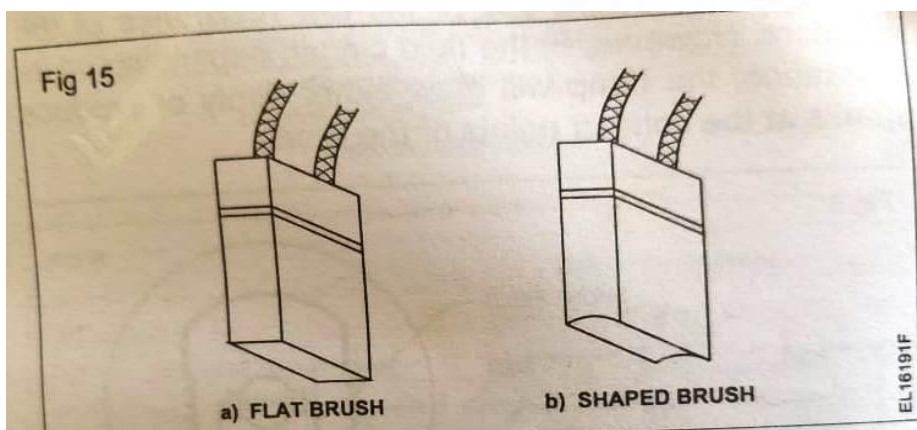
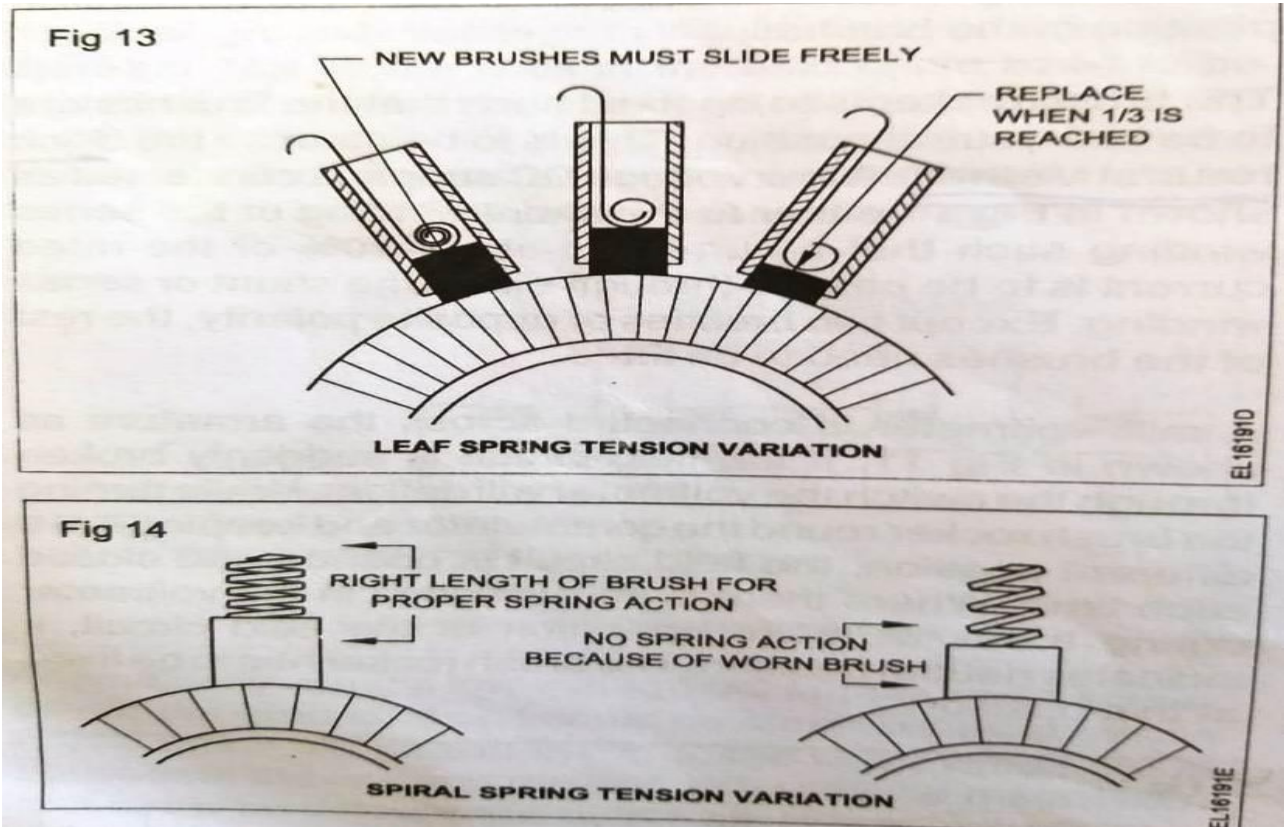

Bearing and End plate: -

A bearing is a machine element which are used to reduce friction between moving parts. In DC machines ball and roller bearing are generally used which are filled with grease or lubricating oils. The bearings are housed in these end plates and they are fixed to the yoke. They help the armature for frictionless rotation and to position the armature in the air gap of the field poles.

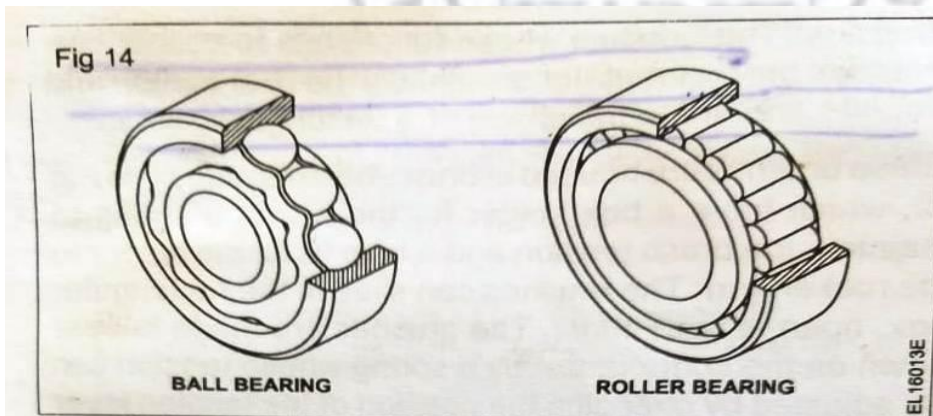
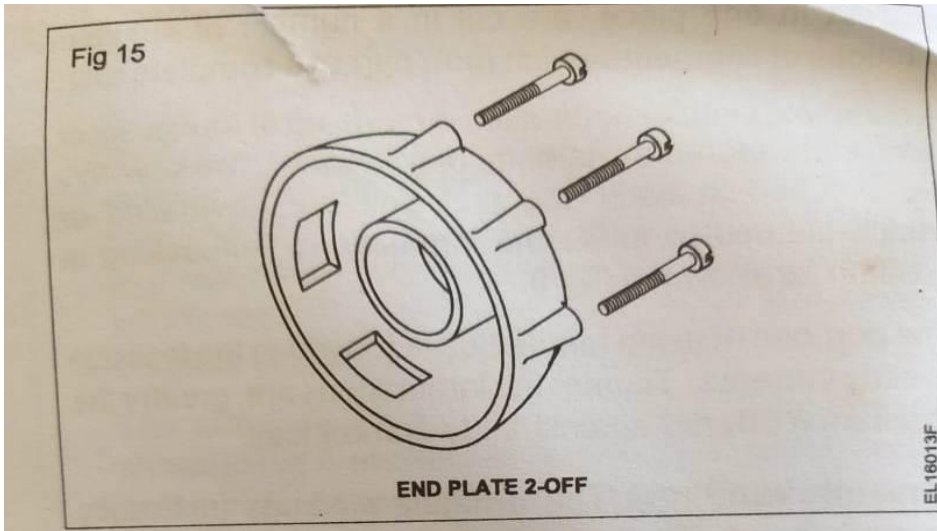

Cooling Fan: - Cooling fan are placed on the shaft of Dc machine which mainly used for cooling purpose.

Shaft: - A shaft is a mechanical component for transmitting torque and rotation. It is cylindrical in shape and made of cold rolled or hot rolled steel.

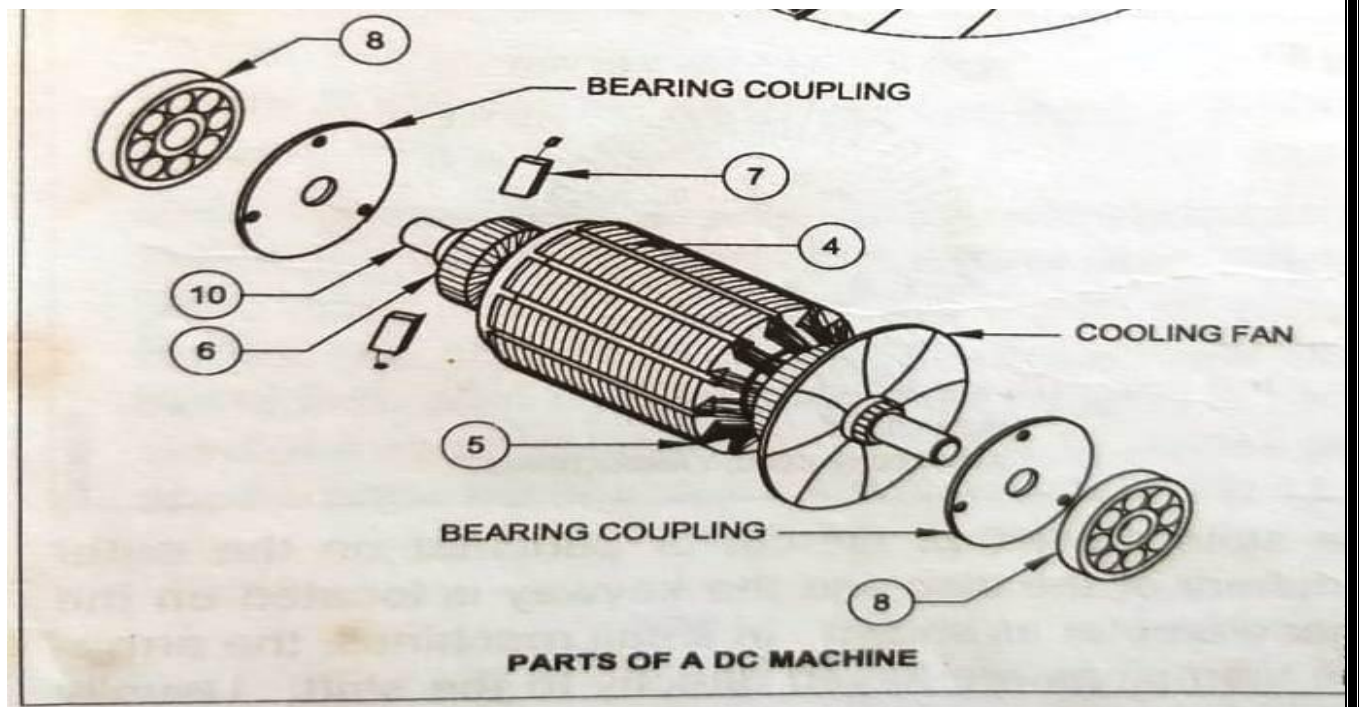

Terminal Box:- Terminal box in dc machines are placed on the yoke. It is used for connection of machine winding terminal and supply terminal.

Name Plate:- It is placed on the yoke which indicates the machine in formations like capacity, rpm, wattage, insulation class etc.

Conclusion: -

From this experiment, we learnt about the various parts of Dc machine.

DISCUSSION QUESTION

1. The yoke is made of which material and why?.
2. The commutator is made of which material and why?
3. What is the function of brushes?
4. Why the field pole shoes are curved in nature?
5. State Fleming's Right Hand rule?

Experiment – 3

AIM OF THE EXPERIMENT: - To obtain the open circuit characteristics of DC shunt generator and find its critical resistance.

APPARATUS REQUIRED:

Sl.no	Name of the Equipment	Specification	Quantity
1	DC shunt Generator	220v, 3 KW, 1500 RPM, 10.5A	01 No
2	3 Point Starter	20 A	01 No
3	Ammeter	(0-1)A MC	01 No
4	Voltmeter	(0-300)V MC	01 No
5	Rheostats	1250 ohm ,0.8A Wire Wound	01 No
6	SPST Switch	---	01 No
7	Tachometer	Digital	01 No
8	Connecting Wires	2.5sq.mm. Copper	As per required

THEORY:

1. Open Circuit Characteristic (O.C.C.) (E_0/I_f)

Open circuit characteristic is also known as **magnetic characteristic** or **no-load saturation characteristic**. This characteristic shows the relation between generated emf at no load (E_0) and the field current (I_f) at a given fixed speed. The O.C.C. curve is just the magnetization curve and it is practically similar for all type of generators. The data for O.C.C. curve is obtained by operating the generator at no load and keeping a constant speed. Field current is gradually increased and the corresponding terminal voltage is recorded. The connection arrangement to obtain O.C.C. curve is as shown in the figure below. For shunt or series excited generators, the field winding is disconnected from the machine and connected across an external supply.

Now, from the emf equation of dc generator, we know that $E_g = k\phi$. Hence, the generated emf should be directly proportional to field flux (and hence, also directly proportional to the field current). However, even when the field current is zero, some amount of emf is generated (represented by OA in the figure below). This initially induced emf is due to the fact that there exists some residual magnetism in the field poles. Due to the residual magnetism, a small initial emf is induced in the armature. This

initially induced emf aids the existing residual flux, and hence, increasing the overall field flux. This consequently increases the induced emf. Thus, O.C.C. follows a straight line. However, as the flux density increases, the poles get saturated and the ϕ becomes practically constant. Thus, even we increase the I_f further, ϕ remains constant and hence, E_g also remains constant. Hence, the O.C.C. curve looks like the B-H characteristic.

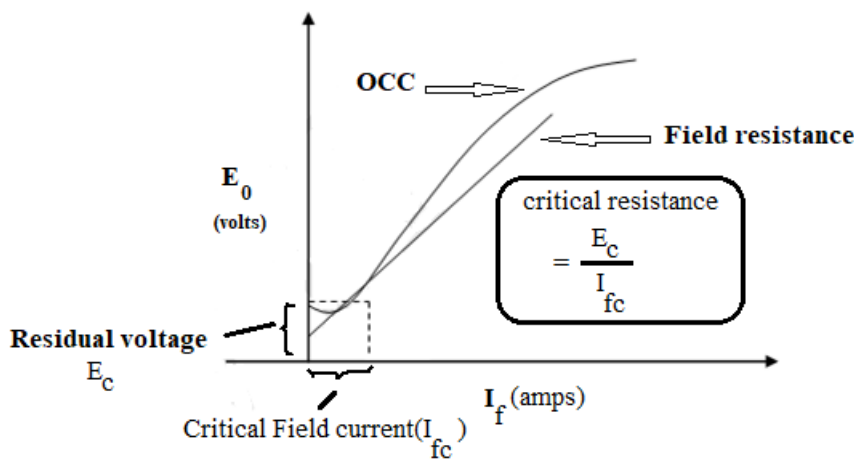

Fig.2. OCC curve of a dc shunt generator

CIRCUIT DIAGRAM:

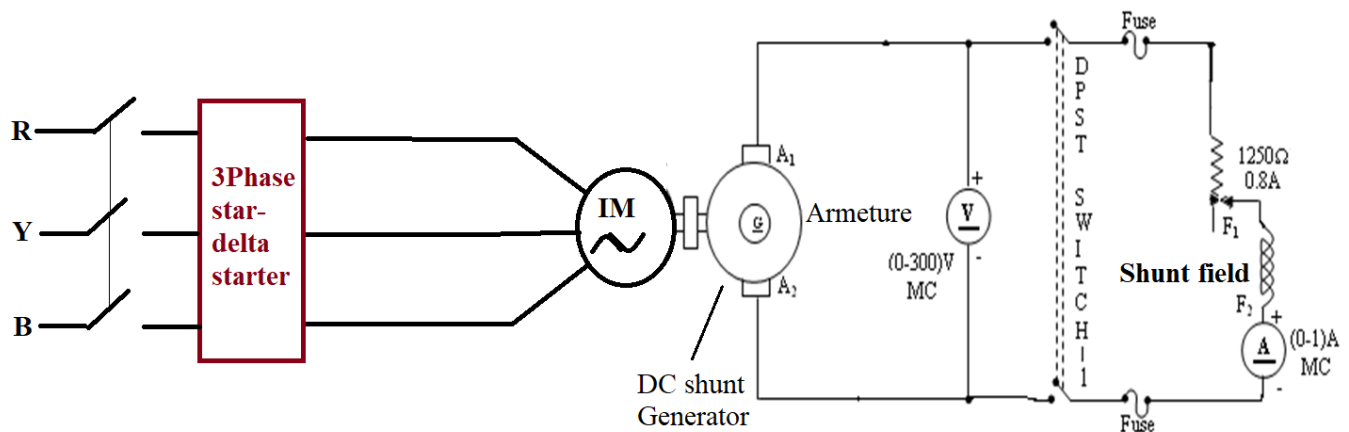

Fig.3. Circuit Diagram for Draw OCC Characteristics of DC Shunt Generator

OBSERVATION TABLE:

Sl.No	Field Current I_f (Amps)	Armature Voltage E_o (Volts)

PROCEDURE:

1. Connections are made as per the circuit diagram.
2. By adjusting the Supply Voltage, the motor is brought to its rated speed.
3. Voltmeter and ammeter readings are taken when the DSPST switch is kept open.
4. After closing the DSPST switch, by varying the generator field rheostat, voltmeter and ammeter readings are taken.

PRECAUTION:

- The field rheostat of generator should be in maximum resistance position at the time of starting and stopping of the machine.

CONCLUSION

DISCUSSION QUESTION

1. What is the critical resistance?
2. What is residual voltage?
3. Where is star-delta starter used?

Experiment – 4

AIM OF THE EXPERIMENT: - Plot External characteristics of a DC shunt generator at constant speed.

APPARATUS REQUIRED:

Sl.no	Name of the Equipment	Specification	Quantity
1	DC shunt Generator	220v, 3 KW, 1500 RPM, 10.5A	01 No
2	3 Point Starter	15 A	01 No
3	Ammeter	(0-1)A MC (0-20)A MC	01 No 01 No
4	Voltmeter	(0-300)V MC	01 No
5	Rheostats	1250 ohm ,0.8A Wire Wound	01 No
6	SPST Switch	---	01 No
7	Tachometer	Digital	01 No
8	Connecting Wires	2.5sq.mm. Copper	As per required

THEORY:

Load characteristics are study of voltage when the load on a generator is increased from no load or decreased from full load.

There are two types of characteristics

- (i) External characteristics
- (ii) Internal characteristics

External characteristics

A plot of the terminal voltage V_T and load current I_L with preset values of field current and speed gives External characteristics curve. The drop in terminal voltage V_T is due to armature reaction and further reduction is due reduction in field current I_f , since the terminal voltage fallen because of the above two reasons.

CIRCUIT DIAGRAM:

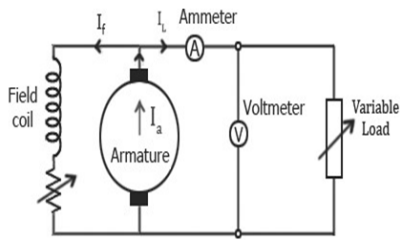

Fig.1. Circuit Diagram for External Characteristic of dc shunt generator

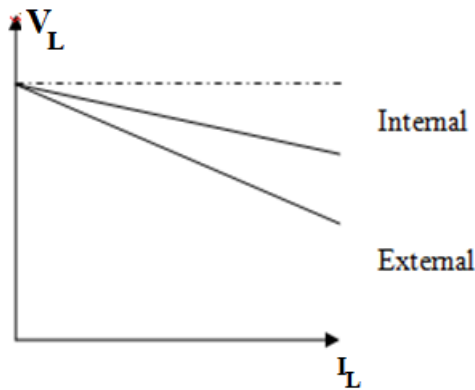

Fig.2. shows the external characteristics of dc shunt generator

OBSERVATION TABLE:

Sl. No	Load Current (I_L) in ampere	Terminal Voltage (V_T) in Volt

PROCEDURE:

- i. Connections are made as shown in fig-1.
- ii. Motor is switched ON by dragging the star-delta starter handle slowly downward (star position) till motor attains 70% of rated speed then drag into

- delta position to run the motor at rated speed.
- iii. by adjusting the field of generator keep the terminal voltage V_L around 220V (rated voltage)
 - iv. Load the generator by keeping the speed of generator constant and note the values of V_L , I_L , and I_f .
 - v. Repeat step 4 till the rated load current is attained.
 - vi. Reduce the load and switch off the supply
 - vii. Plot the load characteristics as external and internal characteristics

PRECAUTION:

- The field rheostat of generator should be in maximum resistance position at the time of starting and stopping of the machine.

CONCLUSION

DISCUSSION QUESTION

4. What are external characteristics and internal characteristics of a dc shunt generator?
5. Where is a star-delta starter used?

ITT CHOUDWAR

Experiment – 5

AIM OF THE EXPERIMENT: - Study of three-point starter, connect and run a DC shunt motor and measure the no load current.

APPARATUS REQUIRED:

Sl.no	Name of the Equipment	Specification	Quantity
1	DC Shunt Motor	220v, 2 KW, 1500 RPM, 10.5A	1no
2	Insulated Combination Pliers	150mm	1no
3	3 Point Starter	20 A	1no
4	Screw driver	200mm	1no
5	Series test lamp board	220V	1no
6	Double ended Spanner	-----	1 Set
7	Connection wires		As per required

THEORY:

The primary function of a starter is to limiting the starting current. At the starting time of the motor the back emf is zero. So at starting time the current is dangerously high. Hence a motor can be damaged. So starter is used to minimize the starting current. The face plate box type starter used for starting shunt and compound motor of ordinary, industrial capacity are of two types, known as 3 point and 4 point starter respectively.

3 Point Starter:-

There are three terminals available in this starter and it is named as 3-point starter, which is marked as L, Z, A. The three-point starter terminals are line, field and armature. The terminal L is connected to the positive of main supply (+), the other line (-) is connected to one armature terminal and field terminal which are tied together. Point A is further connected to starting arm through over current release coil or over load release coil (M) to start the motor. The main switch is closed then the starting arm is slowly moved to the right. As soon as the arm make contact with stud no1, the field circuit is directly connected across the line at the same time full starting resistance is placed in series with the armature. The starting current drawn by the

$$I_a = V / (R_a + R_s)$$

R_a = armature resistance

R_s = Starting resistance

As the arm is further move the starting resistance is gradually, cut out till when the arm reaches the running position the resistance is all cut-outs.

The arm moves over the various studs again a starting force which tends to restore an off position.

There is a soft iron piece attached to the arm which in the full on running position is attracted and held by the shunt current. It is also known as hold on coil or low voltage release coil.

The arm is moved from stud no 1 to the last stud the current has to travel back through the point of starting resistance that has been cut out the armature circuit. This result slide decrease of shunt current but as the value of starting resistance is very small as compared to shunt field resistance; this slide decrease in I_{sh} is negligible. This effect can remedy by using a brush field circuit is completed through the starting resistance. The action of two protective devices of 3 point starter.

FUNCTION OF NO-LOAD RELEASE COIL

- i. The function of hold on coil is to hold on the arm in the full running position then motor is in normal operation. In cases of failure or disconnection of the supply to the off position.
- ii. This prevents the stationary armature from the input across the line again when the supply is restoring after temporary shutdown.
- iii. Advantage of connecting the hold on coil is in series with the shunt field is that when the field circuit becomes open, the starting arm immediately spring back to the off position the motor from running away.

FUNCTION OF OVER LOAD RELEASE COIL

- ii. Overload release coil consist of an electromagnet connected in the supply line. If the motor became over loaded beyond a certain predetermined value than the iron piece (D) is lifted and short circuit the electromagnet. Hence, the arm is released and returns to off position.
- iii. The 3 point starter can't be used in variable speed motor to overcome this drawback 4 point starter is used in dc motor.

Necessity of Starter:-

- (i) Starter is used to protect Dc motor from damage which can be caused by very high current and torque during starting.
- (ii) Starting of DC motor, the armature is stationary, thus the back emf is also zero which is proportional to speed.
- (iii) As armature resistance is very small, if the voltage is applied to it, it will draw many times of full load current.
- (iv) This can cause heavy damage to the armature, so the starting current should be limited to a safe value.
- (v) This can be done by inserting a resistance in series with the armature at the time of starting for a period of 5 to 10 sec.

circuit diagram

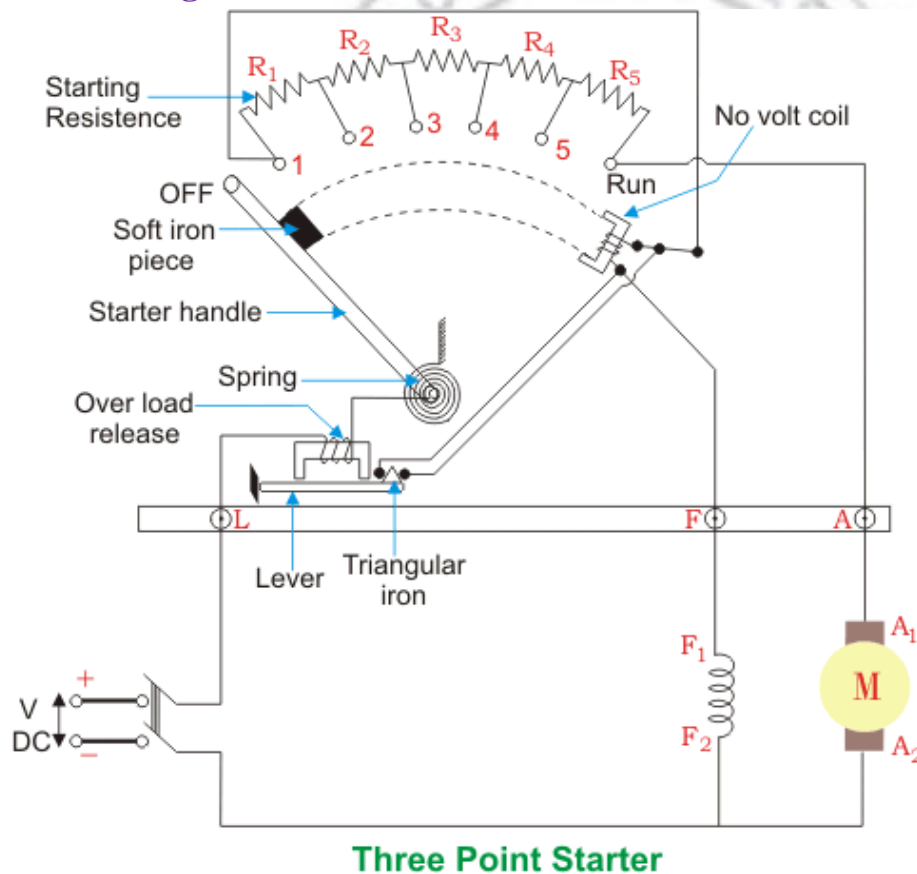

PROCEDURE:

- I. We should take all the tools & instrument for this experiment.
- II. Connect the Starter as per circuit diagram with DC compound Motor.
- III. Check all the connection.
- IV. Switch on the D.C. Supply start the motor with the help of starter.
- V. Gradually increase the starter handle to the holding coil.
- VI. Measure the starting No load current.

OBSERVATION

No load current=_____amp , No load speed=_____rpm

CONCLUSION

DISCUSSION QUESTION

1. Write the function of no volt coil?
2. Where the function of over load release coil?
3. Where is three point starter used?
4. What is the material used for making stud used in 3 point starter?

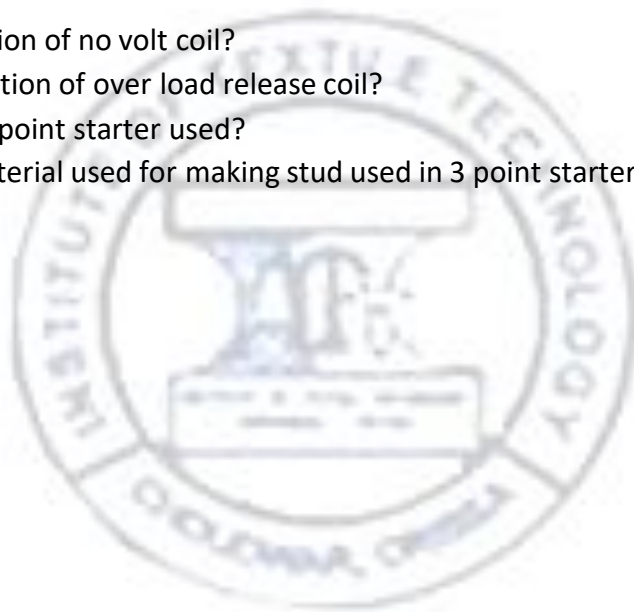

ITT CHOUDWAR

Experiment – 6

AIM OF THE EXPERIMENT: - Study of four-point starter, connect and run a DC shunt motor and measure the no load current.

APPARATUS REQUIRED:

Sl.no	Name of the Equipment	Specification	Quantity
1	DC Compound Motor	220v, 2 KW, 1500 RPM, 10.5A	1no
2	Insulated Combination Pliers	150mm	1no
3	4 Point Starter	220v, 10 A	1no
4	Screw driver	200mm	1no
5	Series test lamp board	220V	1no
6	Double ended Spanner	-----	1 Set
7	Connection wires		As per required

THEORY:

The primary function of a starter is to limiting the starting current. At the starting time of the motor the back emf is zero. So at starting time the current is dangerously high. Hence a motor can be damaged. So starter is used to minimize the starting current. The face plate box type starter used for starting shunt and compound motor of ordinary, industrial capacity are of two types, known as 3 point and 4 point starter respectively.

Necessity of Starter:-

- (i) Starter is used to protect Dc motor from damage which can be caused by very high current and torque during starting.
- (ii) Starting of DC motor, the armature is stationary, thus the back emf is also zero which is proportional to speed.
- (iii) As armature resistance is very small, if the voltage is applied to it, it will draw many times of full load current.
- (iv) This can cause heavy damage to the armature, so the starting current should be limited to a safe value.
- (v) This can be done by inserting a resistance in series with the armature at the time of starting for a period of 5 to 10 secs.

Four- Point Starter:-

- (i) It is used to start the dc compound motor.
- (ii) It is similar to 3-point starter but here the holding coil is not

- connected in series with the shunt field.
- (iii) It is connected across the supply in series with a resistor. This resistor limits the current in the holding coil to the desired value.
- (iv) If the line voltage drops below the desired value, the magnetic attraction of the holding coil is decreased and then the spring pulls the starter handle back to the 'off' position.

FUNCTION OF NO-LOAD RELEASE COIL

- iv. The function of hold on coil is to hold on the arm in the full running position then motor is in normal operation. In cases of failure or disconnection of the supply to the off position.
- v. This prevents the stationary armature from the input across the line again when the supply is restoring after temporary shutdown.
- vi. Advantage of connecting the hold on coil is in series with the shunt field is that when the field circuit becomes open, the starting arm immediately spring back to the off position the motor from running away.

FUNCTION OF OVER LOAD RELEASE COIL

- iv. Overload release coil consist of an electromagnet connected in the supply line. If the motor became over loaded beyond a certain predetermined value than the iron piece (D) is lifted and short circuit the electromagnet. Hence, the arm is released and returns to off position.
- v. The 3 point starter can't be used in variable speed motor to overcome this drawback 4 point starter is used in dc motor.

circuit diagram

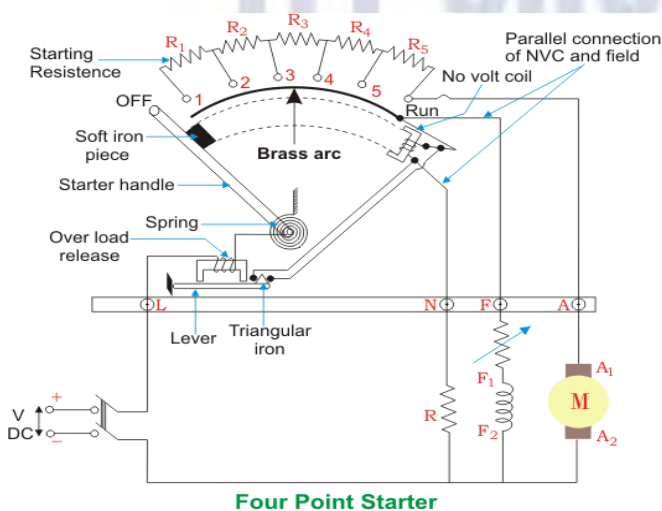

PROCEDURE:

- VII. We should take all the tools & instrument for this experiment.
- VIII. Connect the Starter as per circuit diagram with DC compound Motor.
- IX. Check all the connection.
- X. Switch on the D.C. Supply start the motor with the help of starter.
- XI. Gradually increase the starter handle to the holding coil.
- XII. Measure the starting No load current.

OBSERVATION

No load current=_____ amp , No load speed=_____ rpm

CONCLUSION

DISCUSSION QUESTION

1. Write the function of no volt coil?
2. Where the function of over load release coil?
3. Where is four point starter used?
4. What is the material used for making stud used in 4 point starter?

ITT CHOUDWAR

Experiment – 7

AIM OF THE EXPERIMENT: - Control the speed of a DC shunt motor by field flux control method & armature voltage control method.

APPARATUS REQUIRED:

Sl.no	Name of the Equipment	Specification	Quantity
1	DC Compound Motor	220v, 2 KW, 1500 RPM, 10.5A	1no
2	3-point starter	220v, 10 A	1no
3	Ammeter	0-20A, MC	1no
4	Voltmeter	0-300V, MC	1no
5	Rheostats	1250 Ohm, 0.8A Wire wound	1no
		50 Ohm, 3.5A Wire wound	1no
6	Tachometer	Digital type	1 Set
7	Connection wires		As per required

THEORY:

SPEED CONTROL OF DC SHUNT MOTOR

1. VARIATION OF FLUX OR FLUX CONTRL METHOD

We know that $N \propto 1/\Phi$. By decreasing the flux, the speed can be increased and vice versa. Hence, the name flux or field control method. The flux of a dc motor can be changed by changing shunt current I_{sh} with help of a shunt field rheostat. Since shunt current I_{sh} is relatively small, shunt field rheostat has to carry only a small current, which means I^2R loss is small, so that rheostat is small in size. This method is, therefore, very efficient in non-inter-polar machine, the speed can be increased by this method in the ratio 2:1. Any further weakening of flux Φ adversely affects the commutation and hence puts a limit to the maximum speed obtainable with this method. In machine fitted with interpoles, a ratio of maximum to minimum speed 6:1 is fairly common.

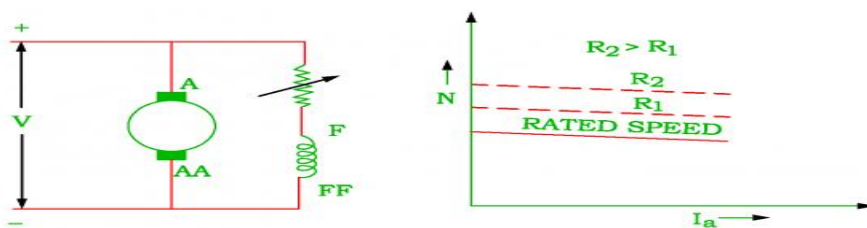
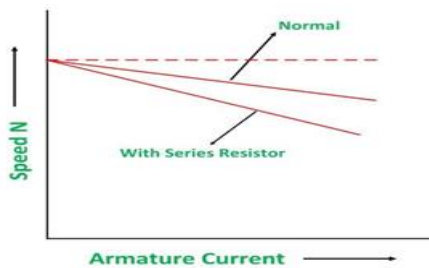

FIG A : FLUX CONTROL

2. ARMATURE OR VOLTAGE CONTROL METHOD

This method is used when speed below the no-load speed are required. As the supply voltage is normally constant, the voltage across the armature is varied by inserting a variable rheostat or resistance (called controller resistance) in series with the armature circuit as shown in fig. As controller resistance is increased, pd across armature is decreased, thereby decreasing the armature speed. For a load constant torque, speed is approximately proportional to the pd across the armature. From the speed vs armature current characteristic, it is seen that greater the resistance in the armature circuit, greater is the fall in speed.



➤ Let I_{a1} = armature current in 1st case

I_{a2} = armature current in 2nd case (if $I_{a1} = I_{a2}$ then load is of constant torque)

N_1, N_2 = corresponding speed,

V = supply voltage

• Then $N_1 \propto V - I_{a1}R_a \propto E_{b1}$

➤ Let some controller resistance of value R be added to the armature circuit resistance so that its value become $(R + R_a) = R_r$

• **Then $N_2 \propto V - I_{a2}R_a \propto E_{b2} \therefore N_2/N_1 = E_{b2}/E_{b1}$**

(In fact, it is a simplified form of relation given because here $\Phi_1 = \Phi_2$)

➤ Considering no load speed, we have $N/N_0 = V - I_a R_t / (V - I_{a0}R_a)$

Neglecting $I_{a0}R_a$ w.r.t V ,

• **we get $N = N_0(1 - I_a R_t / V)$**

➤ It is seen that for a given resistance R_t the speed is a linear function of armature current I_a .

➤ The load current for which the speed would be zero is found by putting $N=0$ in the above relation

• **$\therefore 0 = N_0(1 - I_a R_t / V)$ or $I_a = V / R_t$**

➤ This is the maximum current and is known as stalling current.

As will be shown in the diagram this method is very wasteful, expensive and unsuitable for rapidly changing load because for a given value of R_t , speed will change with load. A more stable operation can be obtained by using a diverter across the armature in addition to armature control resistance. Now the changes in armature current (due to changes in the load torque) will not be so effective in changing the pd across the armature (and hence the armature speed).

circuit diagram

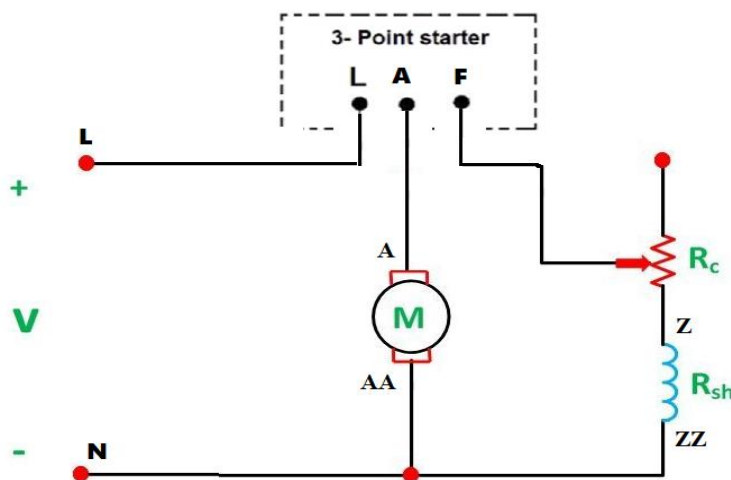

Fig.1. Speed control of DC Shunt motor by field flux control method

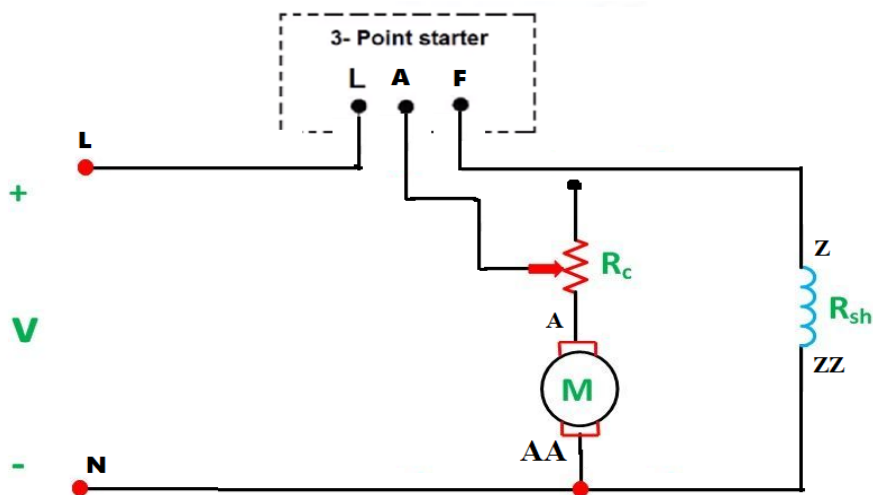

Fig.1. Speed control of DC Shunt motor by armature voltage control method

PROCEDURE:

1. Connections are made as per the circuit diagram.
2. After checking the maximum position of armature rheostat and minimum position of field rheostat, DPST switch is closed

(i) Armature Control:

S.No.	$I_{f1} =$		$I_{f2} =$		$I_{f3} =$	
	Armature Voltage V_a (Volts)	Speed N (rpm)	Armature Voltage V_a (Volts)	Speed N (rpm)	Armature Voltage V_a (Volts)	Speed N (rpm)

1. Field current is fixed to various values and for each fixed value, by varying the armature rheostat, speed is noted for various voltages across the armature.

(ii) Field Control:

1. Armature voltage is fixed to various values and for each fixed value, by adjusting the field rheostat, speed is noted for various field currents.
2. Bringing field rheostat to minimum position and armature rheostat to maximum position DPST switch is opened.

OBSERVATION TABLE

(i) Armature Voltage Control:

(i) Field Flux Control:

S.No.	$V_{a1} =$		$V_{a2} =$		$V_{a3} =$	
	Field Current I_f (A)	Speed N (rpm)	Field Current I_f (A)	Speed N (rpm)	Field Current I_f (A)	Speed N (rpm)

CONCLUSION

DISCUSSION QUESTION

1. Write the methods to control the speed of a DC shunt motor?
2. Explain the armature voltage control method?
3. What is back emf?
4. What is Lenz's law?
5. What are the different methods to control speed of dc motor?
6. Explain the method of speed control by field control method?
7. Explain the characteristics (electrical) of dc shunt motor?
8. What is critical resistance?

ITT CHOUDWAR

Experiment – 8

AIM OF THE EXPERIMENT: - Determine the armature current vs. speed characteristic of a DC motor

APPARATUS REQUIRED:

Sl.no	Name of the Equipment	Specification	Quantity
1	Dc Series Motor	220v, 1500 RPM, 3KW	1no
2	DC Shunt Motor	220v, 1500 RPM,3KW	1no
3	DC Compound Motor	220v, 1500 RPM, 3KW	1no
4	Tachometer	Digital Type, (0-9999) rpm	1no
5	DC Ammeter	(0-5)A	1no
6	DC Voltmeter	(0-300)V	1no
7	Connection wires	2.5 sq. mm	As per required

THEORY:

1. Dc Series Motor:-

We know the relation, $N \propto E_b / \phi$

For small load current (and hence for small armature current) change in back emf E_b is small and it may be neglected. Hence, for small currents speed is inversely proportional to ϕ . As we know, flux is directly proportional to I_a , speed is inversely proportional to I_a . Therefore, when armature current is very small the speed becomes dangerously high. That is why a series motor should never be started without some mechanical load.

But, at heavy loads, armature current I_a is large. And hence, speed is low which results in decreased back emf E_b . Due to decreased E_b , more armature current is allowed.

• Characteristic of DC Series Motor

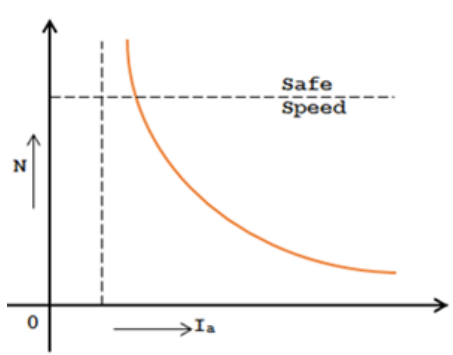

2. DC Shunt Motor:-

As flux ϕ is assumed to be constant, we can say $N \propto E_b$. But, as back emf is also almost constant, the speed should remain constant. But practically, ϕ as well as E_b decreases with increase in load. Back emf E_b decreases slightly more than ϕ , therefore, the speed decreases slightly. Generally, the speed decreases only by 5 to 15% of full load speed. Therefore, a shunt motor can be assumed as a constant speed motor. In speed vs. armature current characteristic in the following figure, the straight horizontal line represents the ideal characteristic and the actual characteristic is shown by the dotted line

- Characteristic of DC Shunt Motor

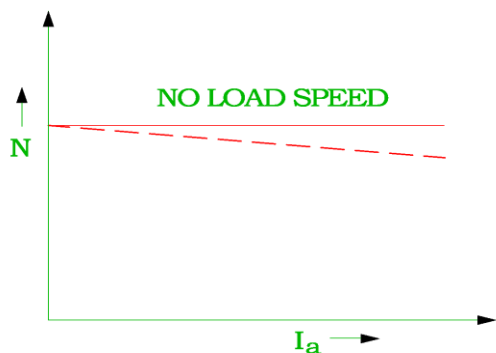

FIG E : SPEED - ARMATURE CURRENT CHARACTERISTIC

3. DC Compound Motor:-

DC compound motors have both series as well as shunt winding. In a compound motor, if series and shunt windings are connected such that series flux is in direction as that of the shunt flux then the motor is said to be cumulatively compounded. And if the series flux is opposite to the direction of the shunt flux, then the motor is said to be differentially compounded. Characteristics of both these compound motors are explained below.

I. Cumulative compound motor

Cumulative compound motors are used where series characteristics are required but the load is likely to be removed completely. Series winding takes care of the heavy load, whereas the shunt winding prevents the motor from running at dangerously high speed when the load is suddenly removed. These motors have generally employed a flywheel, where sudden and temporary loads are applied like in rolling mills.

II. Differential compound motor

Since in differential field motors, series flux opposes shunt flux, the total flux decreases with increase in load. Due to this, the speed remains almost constant or even it may increase slightly with increase in load ($N \propto E_b/\Phi$). Differential compound motors are not commonly used, but they find limited applications in experimental and research work.

- Characteristic of DC Compound Motor

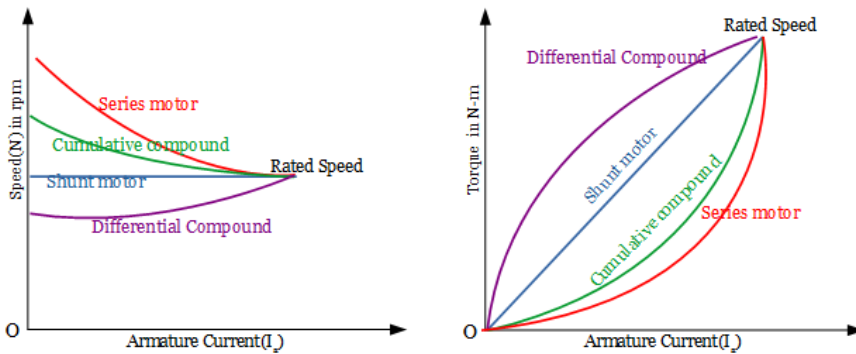

circuit diagram

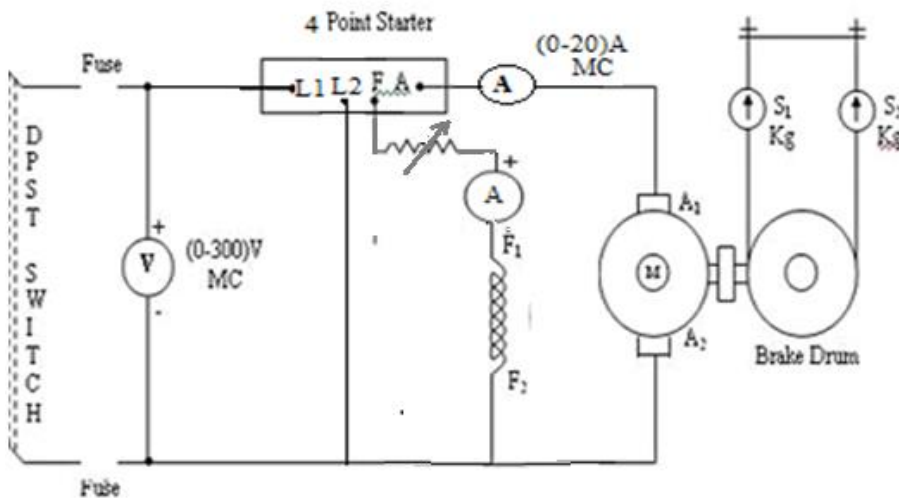

Fig.1. Dc Shunt motor with load

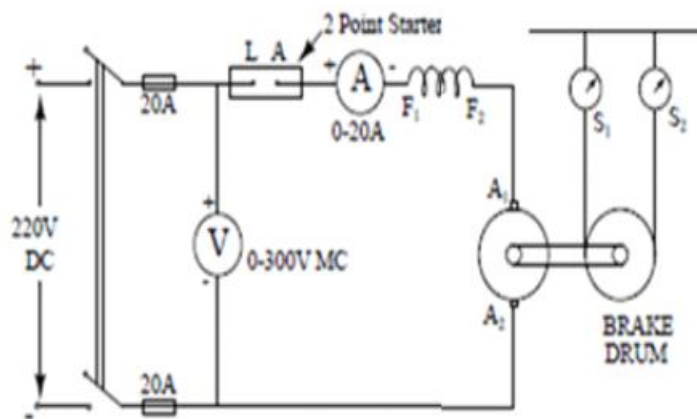

Fig.2. DC Series motor with load

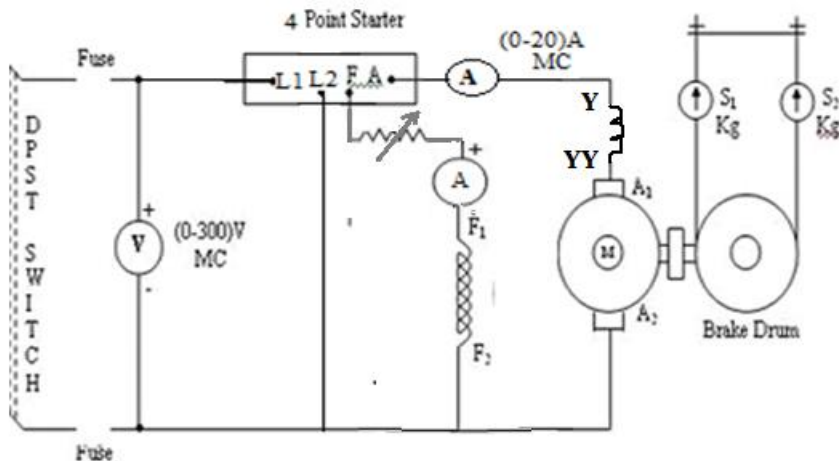

Fig.3. Dc Compound motor with load

PROCEDURE:

3. We should take all the tools & instrument for this experiment.
4. Connect all the motors as per circuit diagram.
5. Check all the connection.
6. Switch on the D.C. Supply start the motor with the help of starter.
7. Gradually increase the starter handle to the holding coil.
8. Measure the starting No load current and full load current of all motors.
9. Measure the speed of all motors with the help of tachometer.
10. by varying the armature rheostat, speed is noted for various voltages across the armature.

OBSERVATION TABLE

SI No	DC Series Motor		DC Shunt Motor		DC Compound Motor	
	Speed(N)	Armature Current (I_a)	Speed(N)	Armature Current (I_a)	Speed(N)	Armature Current (I_a)
1						
2						
3						
4						
5						

CONCLUSION

DISCUSSION QUESTION

9. What is back emf?
10. What is Lenz's law?
11. Explain the characteristics (electrical) of dc shunt motor?
12. What is critical resistance?

ITT CHOUDWAR

Experiment – 9

AIM OF THE EXPERIMENT: - Determine the efficiency of a DC machine by brake test method.

APPARATUS REQUIRED:

Sl.no	Name of the Equipment	Specification	Quantity
1	DC Shunt Motor	220v, 1500 RPM, 3KW, 10.5A	1no
2	3-Point Starter	20A, 220v	1no
3	Tachometer	Digital Type, (0-9999) rpm	1no
4	DC Ammeter	(0-20)A	1no
5	DC Voltmeter	(0-300)V	1no
6	Rheostats	1250 Ohm, 0.8A	1no
7	Connection wires	2.5 sq. mm copper wire	As per required

THEORY:

There are several tests that are conducted upon a DC machine (Motor or Generator) to judge its performance. One important test is performed to measure the efficiency of the DC machine. Efficiency depends on its losses. The smaller the losses the greater is its efficiency and vice versa. The consideration of losses in a DC machine is important because they determine the efficiency of the machine and appreciably influences its operating cost. And also they determine heating of the machine and hence the power output that may be obtained without undue deterioration of the insulation.

In this method a brake drum is connected in the shaft of the motor with spring balances to measure the load. The mechanical output of the motor is calculated with the help of spring balances readings and speed of the machine.

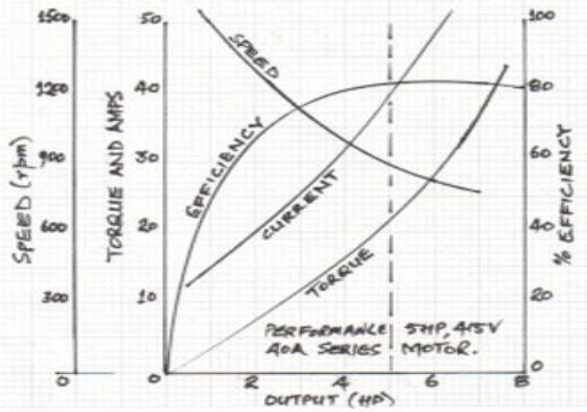

circuit diagram

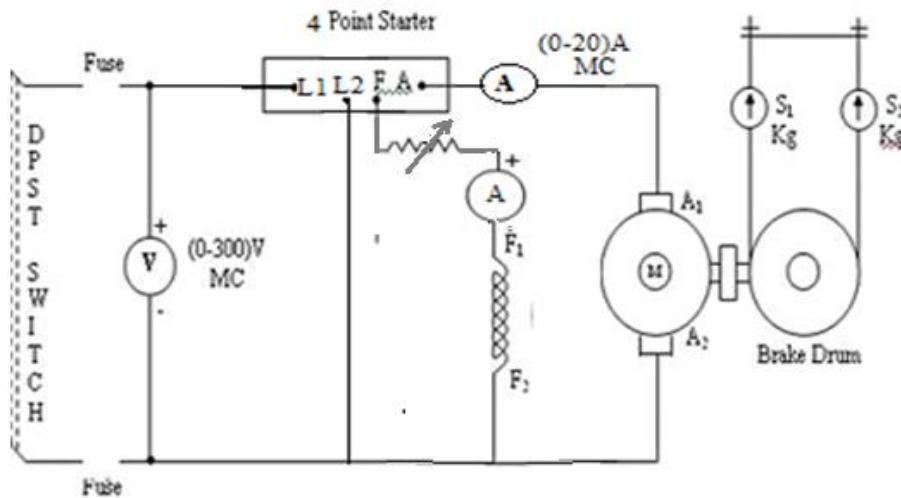

Fig.1. Dc Shunt motor with load

PROCEDURE:

- I. Make the connections as per circuit diagram.
- II. Keep the field regulator of the Motor at minimum Resistance position.
- III. At the time of starting check that the belt on the pulley is free, so that there is no load on the pulley.
- IV. Start the motor slowly by using stator
- V. Adjust the field regulator so that motor runs at its rated speed.
- VI. Apply load on the pulley gradually in steps by adjusting of tension of spring Balance.
- VII. Take the readings of the Ammeter and Voltmeter and two spring balance readings and the speed for each step.
- VIII. Cool the pulley throughout the loading period by pouring water.
- IX. Continue the experiment till full load of the motor is reached.

OBSERVATION TABLE

SL No	V _L (V)	I _L (A)	F ₁ (kg)	F ₂ (kg)	Speed 'N' in RPM	Input Power (w)	Torque (T) in 'Newton meter's	Output Power in		%Efficiency
								Watts	BHP	

CALCULATION

Radius of the Brake drum $r = \dots\dots\dots$ Mtrs

$$\text{Torque}(T) = 9.81 * (F_1 - F_2) * r \quad \text{N.mtr}$$

$$\text{Power Output} = (2 \pi NT / 60) \text{ watts}$$

$$\% \text{Efficiency} = (\text{Output} / \text{Input}) \times 100.$$

CONCLUSION

DISCUSSION QUESTION

13. What is OUTPUT Power?
14. Explain different losses in dc machine?
15. Explain the characteristics (electrical) of dc shunt motor?
16. What is the efficiency?

Experiment – 10

AIM OF THE EXPERIMENT: - Identification of terminals, determination of voltage transformation ratio of a single phase transformer

APPARATUS REQUIRED:

Sl.no	Name of the Equipment	Specification	Quantity
1	1 - ϕ Transformer	230/115V, 1KVA, 50Hz	1no
2	AC Voltmeter	(0-600)V	1no
3	Connection wires	2.5 sq. mm copper wire	As per required
4	Multimeter	Digital Type	1no

THEORY:

Transformation Ratio (K) is defined as the ratio of the EMF in the secondary coil to that in the primary coil.

$$K = E_2/E_1 = (4.44(\Phi_m)fN_2)/(4.44(\Phi_m)fN_1)$$

Therefore,

$$K = E_2/E_1 = N_2/N_1 \dots (1)$$

Now,

$$V_1 = E_1 + \text{voltage drop}$$

$$E_2 = V_2 + \text{voltage drop}$$

Due to the resistance in the windings and some leakage flux, there is some loss in voltage. This is called as Voltage Drop.

But, in ideal case, voltage drop can be neglected. Hence,

$$V_1 = E_1, \quad E_2 = V_2$$

Hence,

$$E_2/E_1 = V_2/V_1 \dots (2)$$

Also, in a transformer, the power across the primary as well as the secondary winding is same. Hence,

$$V_1 \cdot I_1 = V_2 \cdot I_2$$

$$V_1/V_2 = I_2/I_1 \quad (3)$$

Now, combining (1), (2) & (3), we get,

$$K = E_2/E_1 = N_2/N_1 = V_2/V_1 = I_2/I_1$$

Where, 1 represents the primary coil

2 represent the secondary coil

E is emf in the respective coil

V is the voltage in the respective coil

I is the current in the respective coil

N is number of turns of the respective coils

Φ_m is the mutual flux in the core.

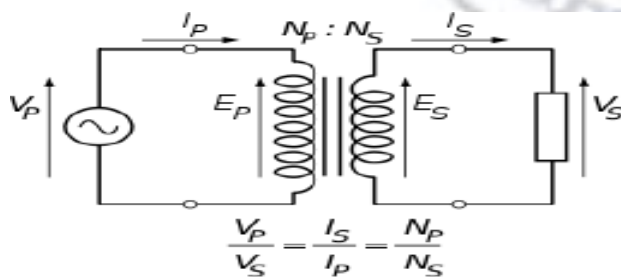

circuit diagram

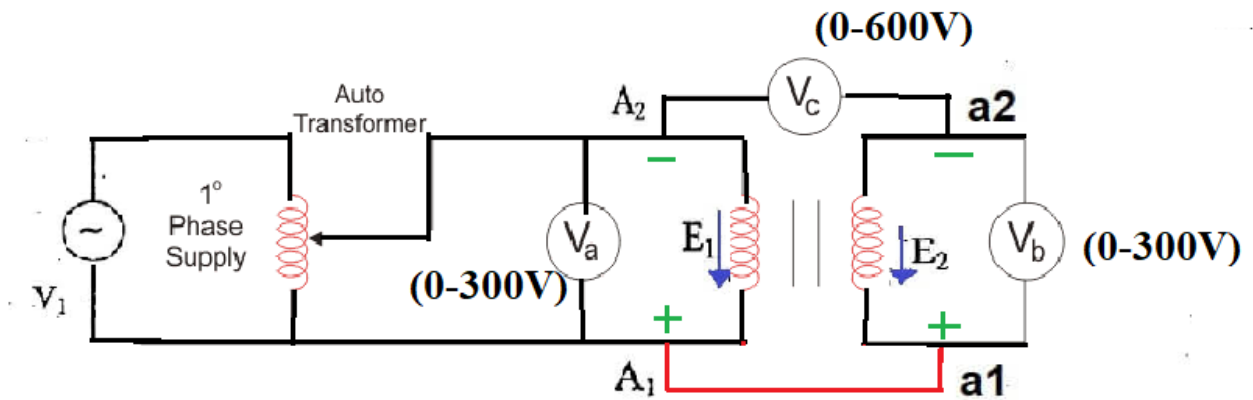

Fig.1. Subtractive polarity

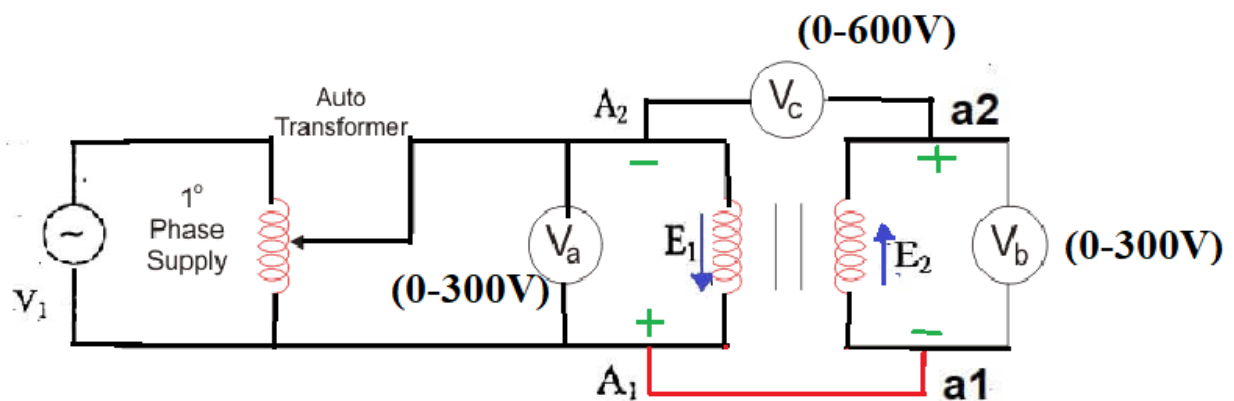

Fig.2. Additive

PROCEDURE:

- i. Connect the primary and secondary coil as shown in fig. Arbitrarily fix the primary winding terminal as A1 & A2 and the secondary terminal as a1 and a2.
- ii. Join A1 & a1 through voltmeter (V) of (0-600)V.
- iii. Connect A2 & a2 in phase and voltage of 230V to the primary.
- iv. If the voltmeter reading is more than presented voltage of 230V, it is an additive polarity marked a1 as -ve & a2 as +ve.
- v. If the voltage read by the voltmeter is less than 230V, it is subtractive polarity and the terminal a1 is to be marked +ve and a2 is -ve for assume polarity of A1 is +ve and A2 is -ve.

OBSERVATION TABLE

FOR ADDITIVE

Sl no	Primary	Secondary	Remark
1			
2			
3			

FOR SUBTRACTIVE

Sl no	Primary	Secondary	Remark
1			
2			
3			

CONCLUSION

DISCUSSION QUESTION:

- i. What is transformer?
- ii. What are the different types of transformer based on construction, explain the diagram?
- iii. What is transformer ratio?
- iv. What is expression for hysteresis loss?
- v. What is eddy current loss?

Experiment – 11

AIM OF THE EXPERIMENT: - Perform OC Test and SC test of a single phase transformer

APPARATUS REQUIRED:

Sl.no	Name of the Equipment	Specification	Quantity
1	Single Phase Transformer	230/115V, 1KVA, 50Hz	1no
2	Ammeter	0-15A 0-5A	1no 1no
3	Voltmeter	(0-300) V	2no
4	Wattmeter	0-150W,230V,5A LPF 0-150W,150V, 15A, ZPF	1no 1no
5	Connecting wires	2.5 sq. mm copper wire	As per required

THEORY:

Open Circuit Test: -

The purpose of the open circuit test is to determine the no-load current and losses of the transformer because of which their no-load parameter are determined. This test is performed on the primary winding of the transformer. The wattmeter, ammeter and the voltage are connected to their primary winding. The nominal rated voltage is supplied to their primary winding with the help of the ac source. The secondary winding of the transformer is kept open and the voltmeter is connected to their terminal. This voltmeter measures the secondary induced voltage. As the secondary of the transformer is open the no-load current flows through the primary winding. The value of no-load current is very small as compared to the full rated current. The copper loss occurs only on the primary winding of the transformer because the secondary winding is open. The reading of the wattmeter only represents the core and iron losses. The core loss of the transformer is same for all types of loads.

Short Circuit Test: -

The short circuit test is performed for determining the below mention parameter of the transformer.

- It determines the copper loss occur on the full load. The copper loss is used for finding the efficiency of the transformer.

- The equivalent resistance, impedance, and leakage reactance are known by the short circuit test.

The short circuit test is performed on the secondary or high voltage winding of the transformer. The measuring instrument like wattmeter, voltmeter and ammeter are connected to the High voltage winding of the transformer. Their primary winding is short-circuited by the help of thick strip or ammeter which is connected to their terminal.

The low voltage source is connected across the secondary winding because of which the full load current flows from both the secondary and the primary winding of the transformer. The full load current is measured by the ammeter connected across their secondary winding.

The low voltage source is applied across the secondary winding which is approximately 5 to 10% of the normal rated voltage. The flux is set up in the core of the transformer. The magnitude of the flux is small as compared to the normal flux.

The iron loss of the transformer depends on the flux. It is less occurred in the short circuit test because of the low value of flux. The reading of the wattmeter only determines the copper loss occur on their windings. The voltmeter measures the voltage applied to their high voltage winding. The secondary current induces in the transformer because of the applied voltage.

circuit diagram

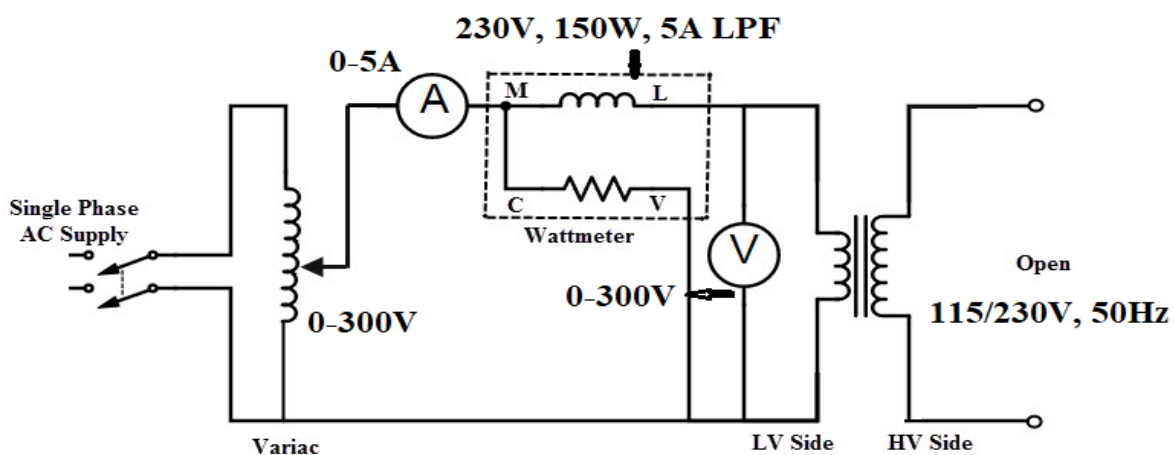

Fig.1. Circuit Diagram for Open Circuit Test of Transformer

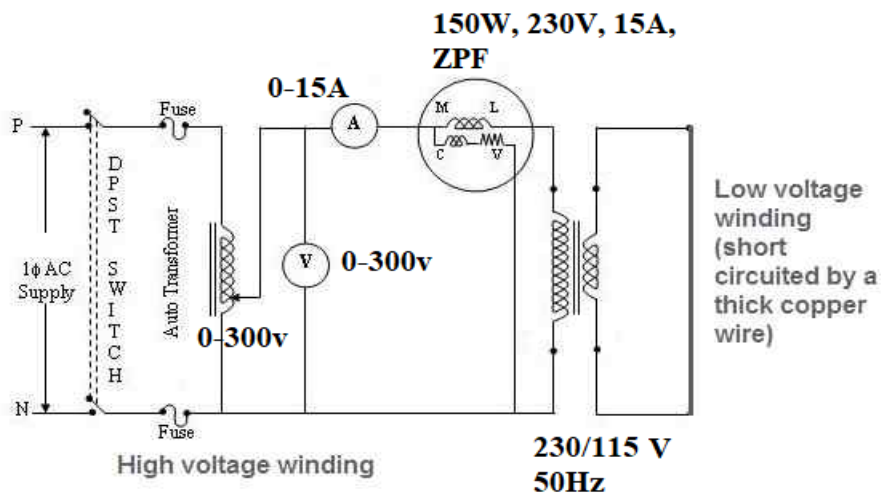

Fig.2. Circuit Diagram for Short- Circuit test of Transformer

PROCEDURE:

OPEN CIRCUIT TEST:

1. Connections are made as per the circuit diagram fig.1.
2. After checking the minimum position of Autotransformer, DPST switch is closed.
3. Auto transformer (variac) is adjusted get the rated primary voltage.
4. Voltmeter, Ammeter and Wattmeter readings on primary side are noted.
5. Auto transformer is again brought to minimum position and DPST switch is opened.

SHORT CIRCUIT TEST:

1. Connections are made as per the circuit diagram fig2.
2. After checking the minimum position of Autotransformer, DPST switch is closed.
3. Auto transformer (variac) is adjusted get the rated primary current.
4. Voltmeter, Ammeter and Wattmeter readings on primary side are noted.
5. Auto transformer is again brought to minimum position and DPST switch is opened.

OBSERVATION TABLE

FOR SHORT-CIRCUIT TEST

V_{sc} (Volts)	I_{sc} (Amps)	W_{sc} (Watts)

FOR OPEN CIRCUIT TEST

V_o (Volts)	I_o (Amps)	W_o (Watts)

CONCLUSION

DISCUSSION QUESTION:

1. What is power factor?
2. What is purpose of performing open circuit test & short circuit test on a transformer?
3. What is all day efficiency?

ITT CHOUDWAR

Experiment – 12

AIM OF THE EXPERIMENT: - Determine the voltage regulation of a single-phase transformer at different loads.

APPARATUS REQUIRED:

Sl.no	Name of the Equipment	Specification	Quantity
1	Single phase transformer	230/115V, 1KVA, 50Hz	1no
2	Ammeter	(0-20) A	1no
3	Voltmeter (AC)	(0-300) V	1no
4	Wattmeter	300V,20A UPF 300V,20A LPF	1no 1no
5	Variac	0-230V, 50Hz	1no
6	Connecting wires	2.5 sq. mm copper wire	As per required
7	Resistive load box	5KW, 230V, 50Hz	1no
8	Inductive load box	2.5KW, 1KVAR, 230V, 50Hz	1no

THEORY:

Transformer is an electrical device which transfers electrical power from one circuit to another circuit without changes in frequency. In other words it is static piece of apparatus by means of which electrical power of the same frequency is transfer into another circuit. It accomplish this circuit by electromagnetic induction and the two electric circuit are in mutual inductive influence of each other.

There are two winding in transformer voltage regulation. It is defined as the change in secondary terminal voltage from no load to full load condition.

$$\text{Voltage regulation} = (V_{01} - V_1) / V_{01}$$

where V_{01} = no load secondary voltage.

V_1 = no load secondary voltage.

$$\text{So \% of voltage regulation} = ((V_{02} - V_2) / V_{02}) \times 100$$

If the regulation of a transformer is in between 5%-10% then the transformer is said to be a good transformer.

circuit diagram

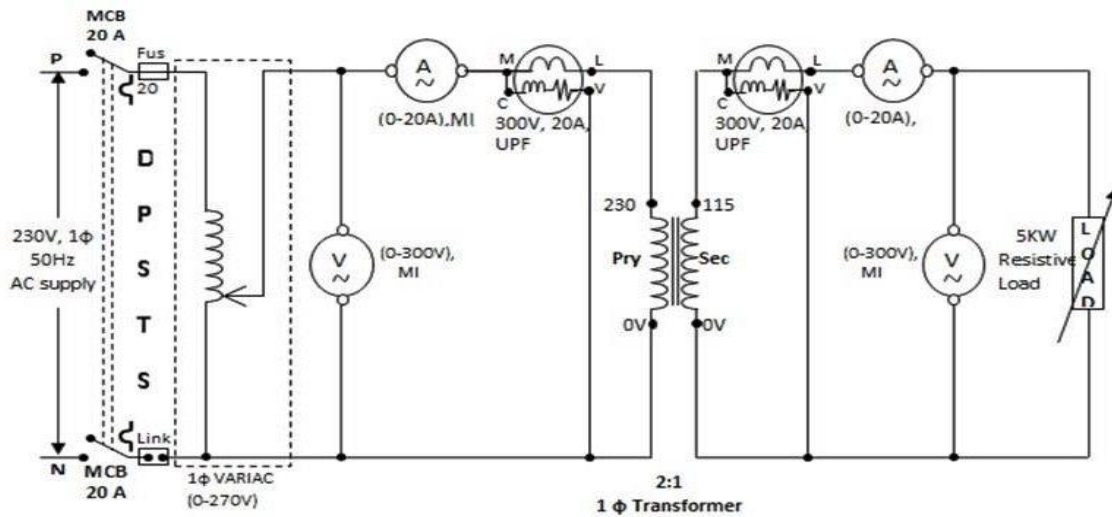

Fig.1. 1-Phase Transformer with resistive load

PROCEDURE:

1. Connections are made as per the circuit diagram fig 1.
2. After checking the no load condition, minimum position of auto transformer and DPST switch is closed.
3. Ammeter, Voltmeter and Wattmeter readings on both primary side and secondary side are noted at no load condition.
4. The load is increased up to rated full load of Transformer and for each load (Resistive load and inductive load), Voltmeter, Ammeter and Wattmeter readings on both primary and secondary sides are noted.

5. Then calculate the regulation of Transformer with each load.

OBSERVATION TABLE

Sl no	Load in watt	No Load voltage in volts	Secondary voltage in volts	Secondary current in amp.	Regulation $((V_{02}-V_2)/V_{02}) \times 100$
1	No load	220			
2	500W (Resistive load)	220			
3	500VAR(Inductive load)	220			
4	750(Resistive load)	220			

CONCLUSION

DISCUSSION QUESTION:

1. What is the voltage regulation of t/f?
2. Write down types of voltage regulation in t/f?
3. What is need of voltage regulation in t/f?

ITT CHOUDWAR

Experiment – 13

AIM OF THE EXPERIMENT: - Polarity test of single-phase transformer and parallel operation of two single phase transformers.

APPARATUS REQUIRED:

Sl.no	Name of the Equipment	Specification	Quantity
1	Single phase transformer	230/115V, 1KVA, 50Hz	2no
2	Ammeter	(0-20) A	2no
3	Voltmeter (AC)	(0-300) V 0-600 V	2no 1no
5	Variac	0-230V, 50Hz	1no
6	Connecting wires	2.5 sq. mm copper wire	As per required

THEORY:

Polarity Test of Transformer :- Polarity means the direction of the induced voltages in the primary and the secondary winding of the transformer. If the two transformers are connected in parallel, then the polarity should be known for the proper connection of the transformer. There are two types of polarity one is **Additive**, and another is **Subtractive**.

Additive Polarity: In additive polarity the same terminals of the primary and the secondary windings of the transformer are connected

Subtractive Polarity: In subtractive polarity different terminals of the primary and secondary side of the transformer is connected.

Each of the terminals of the primary as well as the secondary winding of a transformer is alternatively positive and negative with respect to each other as shown in the figure below.

Let A1 and A2 be the positive and negative terminal respectively of the transformer primary and a1, a2 are the positive and negative terminal of the secondary side of the transformer.

If A1 is connected to a1 and A2 is connected to a2 that means similar terminals of the transformer are connected, then the polarity is said to be additive. If A1 is

connected to a2 and A2 to a1, that means the opposite terminals are connected to each other, and thus the voltmeter will read the subtractive polarity.

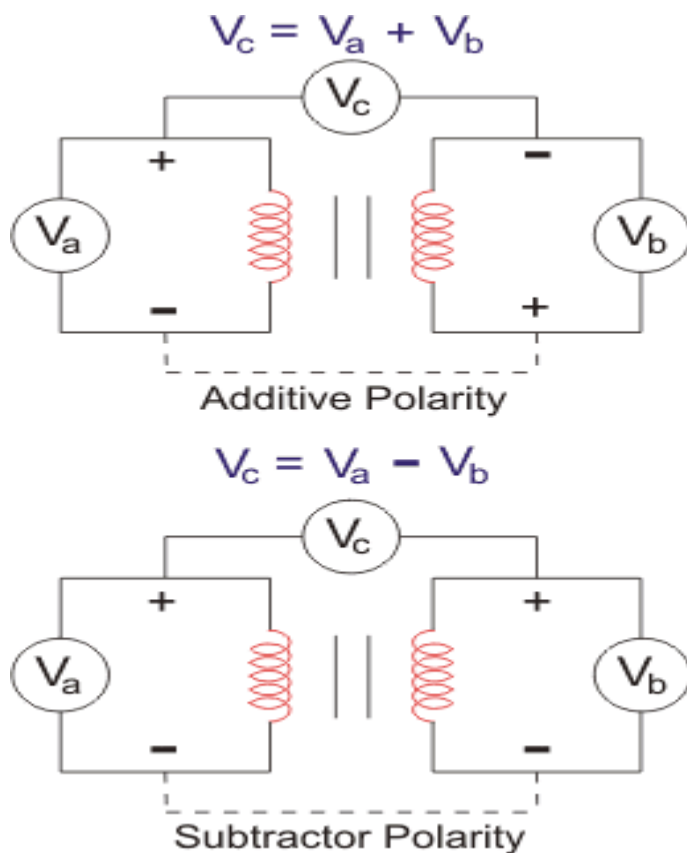

It is essential to know the relative polarities at any instant of the primary and the secondary terminals for making the correct connections if the transformers are to be connected in parallel or they are used in a three phase circuit.

In the primary side, the terminals are marked as A1 and A2 and from the secondary side the terminals are named as a1 and a2. The terminal A1 is connected to one end of the secondary winding, and a voltmeter is connected between A2 and the other end of the secondary winding.

When the voltmeter reads the difference that is $(V_1 - V_2)$, the transformer is said to be connected with opposite polarity known as Subtractive polarity and when the voltmeter reads $(V_1 + V_2)$, the transformer is said to have additive polarity.

Parallel Operation of Two Single Phase Transformers:-

Parallel operation of two or more Transformers means that all the Transformers Primary

is connected with the common supply and their Secondary are feeding to a common bus through which load is connected. Parallel operation of Transformers requires that their Primaries as well as Secondaries are connected in parallel.

Parallel operation of two or more Transformers has many advantages when compared with a single large Transformer. Though using single large Transformer instead of two or more Transformers connected in parallel are cheap but still due to the following advantages, parallel operation of Transformers are preferred where required

With two or Transformers, the Power System becomes more reliable. Let one Transformer develops a fault, then the faulty Transformer can be removed from the circuit while maintaining the power supply at a reduced level through healthy Transformers. Thus in this way, Power System becomes more reliable.

Depending upon the load, Transformers can be switched ON / OFF. In this way, Transformer losses are reduced and the system becomes more efficient and economical.

If the power demand increases with time then extra spare Transformer can be taken into service to meet the power demand.

Condition for Parallel Operation of Transformers:-

When operating two or more transformers in parallel satisfactory performance conditions should be met.

- A) The same voltage ratio
- B) The same per unit (or percentage) impedance
- C) The same polarity
- D) The same phase sequence and zero relative phase displacement

circuit diagram

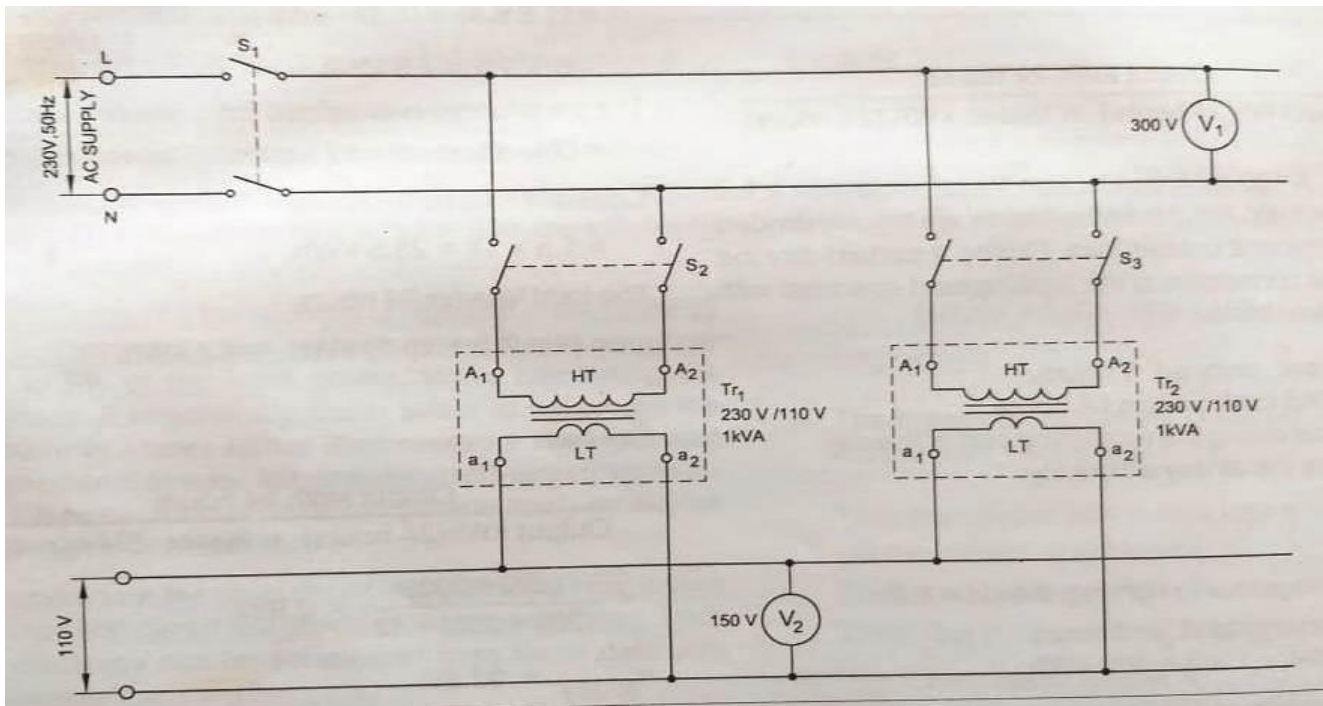

[Parallel Operation of Single Phase Transformer]

PROCEDURE:

Polarity test:-

- Connect the circuit as shown in the above circuit diagram figure and set the autotransformer to zero position.
- Switch on the single phase supply
- Records the values of the voltages as shown by the voltmeter V_1 , V_2 and V_3 .
- If the reading of the V_3 shows the addition of the value of V_1 and V_2 that is $V_3 = V_1 + V_2$ the transformer is said to be connected in additive polarity.
- If the reading of the V_3 is the subtraction of the readings of V_1 and V_2 , then the transformer is said to be connected in subtractive or negative polarity.

Parallel Operation:-

- First, perform the polarity test on each of the units and label or note down terminals with the same polarity
- Also, confirm that no-load secondary voltages of both transformers match in magnitude. If possible, also check the respective instantaneous phase angles. Note: It is important to perform both these tests before attempting the parallel operation.

- c. Perform the SC test to find out leakage impedance parameters of the two transformers. Attempt to calculate the power sharing analytically using equivalent circuit of transformer.
- d. With the primaries in unenergized state, connect a common load across the transformer secondaries, with the load KVA rating not exceeding the total KVA rating of the two units.
- e. Slowly increase the autotransformer voltage until rated voltage appears across the primaries of each transformer.

OBSERVATION TABLE

Sl no	Load i n watt	Primary current (I1)	Load current (I2)	Primary voltage (V1)	Secondary voltage(V 2)	o/p power wattmeter reading	Remark
1	250			200			
2	500			200			
3	750			200			
4	1000			200			
5	1250			200			
6	1500			200			

CONCLUSION

DISCUSSION QUESTION:

- I. What are the conditions of parallel operation of single phase transformer?
- II. What are the advantages parallel operation?
- III. What is load sharing of parallel operation?